

IC Zener Eases Reference Design

National Semiconductor
Application Note 173
November 1976



Description

A new IC zener with low dynamic impedance and wide operating current range significantly simplifies reference or regulator circuit design. The low dynamic impedance provides better regulation against operating current changes, easing the requirements of the biasing supply. Further, the temperature coefficient is independent of operating current, so that the LM129 can be used at any convenient current level. Other characteristics such as temperature coefficient, noise and long term stability are equal to or better than good quality discrete zeners.

The LM129 uses a new subsurface breakdown IC zener combined with a buffer circuit to lower dynamic impedance. The new subsurface zener has low noise and excellent long term stability since the breakdown is in the bulk of the silicon. Circuitry around the zener supplies internal biasing currents and buffers external current changes from the zener. The overall breakdown is about 6.9V with devices selected for temperature coefficients.

The zener is relatively straightforward. A buried zener D1 breaks down biasing the base of transistor Q1. Transistor Q1 drives two buffers Q2 and Q3. External current changes through the circuit are fully absorbed by the buffer transistors rather than by D1. Current through D1 is held constant at 250 μ A by a 2k resistor across the emitter base of Q1 while the emitter-base voltage of Q1 nominally temperature compensates the reference voltage.

The other components, Q4, Q5 and Q6, set the operating current of Q1. Frequency compensation is accomplished with two junction capacitors.

All that is needed for biasing in most applications is a resistor as shown in *Figure 2*. Biasing current can be anywhere from 0.6 mA to 15 mA with little change in performance. Optimally, however, the biasing current should be as low as possible for the best regulation. The dynamic impedance of the LM129 is about 1 Ω and is independent of current. Therefore, the regulation of the LM129 against voltage changes is $1/R_s$.

Lower currents or higher R_s give better regulation. For example, with a 15V supply and 1 mA operating current, the reference change for a 10% change in the 15V supply is 180 μ V. If the LM129 is run at 5 mA, the change is 900 μ V or 5 times worse. By comparison, a standard IN821 zener will change about 17 mV. All discrete zeners have about the same regulation since their dynamic impedance is inversely proportional to operating current.

If the zener does not have to be grounded, a bridge compensating circuit can be used to get virtually perfect regulation, as shown in *Figure 3*. A small compensating voltage is generated across R_1 , which matches the dynamic impedance of the LM129. Since the dynamic impedance of the LM129 is linear with current, this circuit will work even with large changes in the unregulated input voltage.

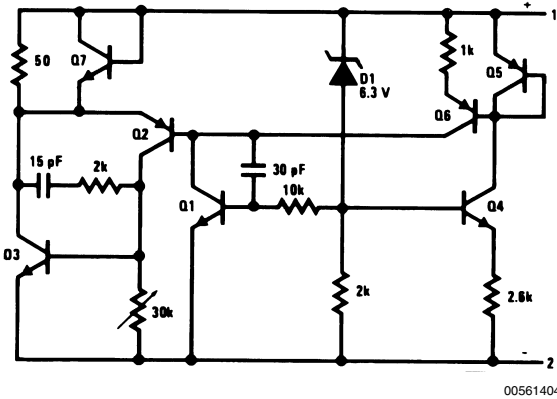

FIGURE 1. IC Reference Zener

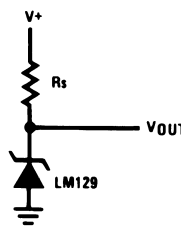
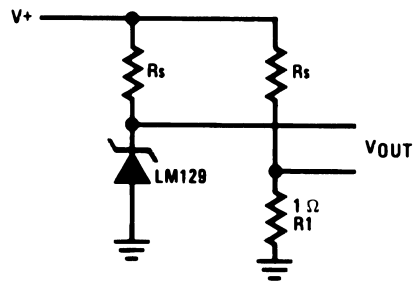

FIGURE 2. Basic Biasing

Other output voltages are easily obtained with the simple op-amp circuit shown in *Figure 4*. A simple non-inverting amplifier is used to boost and buffer the zener to 10V. The reference is run directly from the input power rather than the output of the op-amp. When the zener is powered from the op-amp, special starting circuitry is sometimes necessary to insure the output comes up in the right polarity. For outputs lower than the breakdown of the LM129 a divider can be connected across the zener to drive the op-amp.

An AC square wave or bipolarity output reference can easily be made with an op-amp and FET switch as shown in *Figure 5*. When Q1 is "ON", the LM108 functions as a normal inverting op-amp with a gain of -1 and an output of -6.9 V. With Q1 "OFF" the op-amp acts as a giving 6.9V at the output. Some non-symmetry will occur from loading change on the LM129 in the different states and mismatch of R_1 and R_2 . Trimming either R_1 or R_2 can make the output exactly symmetrical around ground.

Description (Continued)



00561406

FIGURE 3. Bridge Compensation for Line Changes

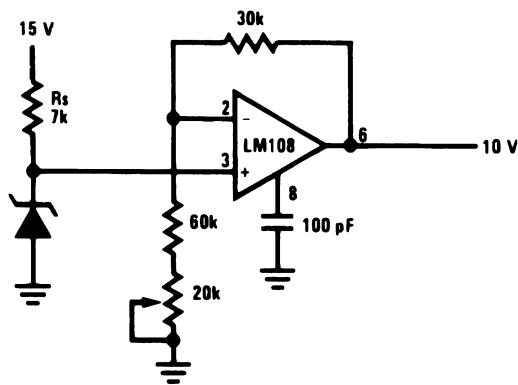

00561408

FIGURE 4. 10 Volt Buffered Output Reference

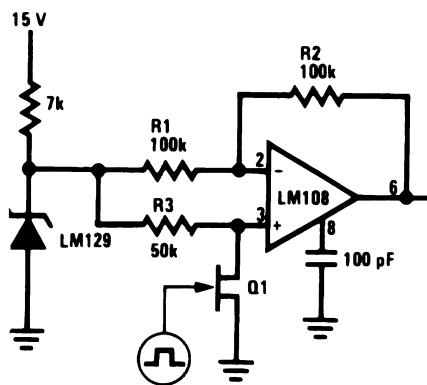

00561407

FIGURE 5. Bipolar Output Reference

Description (Continued)

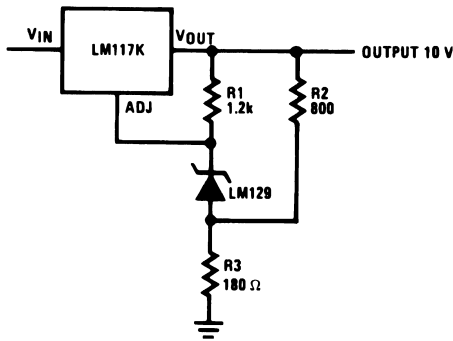

00561409

FIGURE 6. High Stability 10V Regulator

By combining the LM129 with an LM117 three-terminal regulator a high stability power regulator can be made. This is shown in *Figure 6*. Resistor R1 biases the LM129 at about 1 mA from the 1.25V reference in the LM117. The voltage of the LM129 is added to the 1.25V of the LM117 to make a total reference voltage of 8.1V. The output voltage is then set at 10V by R2 and R3. Since the internal reference of the LM117 contributes only about 20% of the total reference voltage, regulation and drift are essentially those of the external zener. The regulator has 0.2% load and line regulation and if a low drift zener such as the LM129A is used overall temperature coefficient is less than 0.002%/°C.

The new zener can be used as the reference for conventional IC voltage regulators for enhanced performance. Noise is lower, time stability is better, and temperature coefficient can be better depending on the device selected. Further, the output voltage is independent of power changes in the regulator.

Figure 7 shows an LM723 using an external LM129 reference. The internal 7V reference is not used and a single resistor biases the LM129 as the reference. The 5k resistor chosen provides sufficient operating current for the zener over the 10V to 40V input voltage range of the LM723. Since the dynamic impedance of the LM129 is so low, the reference regulation against line changes is only 0.02%/V. This is small compared to the regulation of 0.1%/V for the LM723; however, the resistor can be replaced by a 1 mA to 5 mA FET used as a constant current source for improved regulation. When the FET is used reference regulation is easily 0.001%/V. Output voltage is set in the standard manner except that for low output voltages sufficient current must be run through the zener to power the voltage divider supplying the reference to the LM723.

An overload protected power shunt regulator is shown in *Figure 8*. The output voltage is about 7.8V – the 7V breakdown of the LM129 plus the 0.8V emitter-base voltage of the

LM395. The LM395 is an IC, 1.5 A power transistor with complete overload protection on the chip. Included on the chip are current limiting and thermal limiting, making the device virtually blowout-proof. Further, the base current is only 5 μ A, making it easy to drive as a shunt regulator. As the input voltage rises, more drive is applied to the base of the LM395, turning it on harder and dropping more voltage across the series resistance. Should the input voltage rise too high, the LM395 will current limit or thermal limit, protecting itself.

The new IC zener can replace existing zeners in just about any application with improved performance and simpler external circuitry. As with any zener reference, devices are selected for temperature coefficient and operating temperature range. Since the devices are made by a standard integrated circuit process, cost is low and good reproducibility is obtained in volume production.

Finally, since the device is actually an IC, it is packaged in a rugged TO-46 metal can package or a 3-lead plastic transistor package.

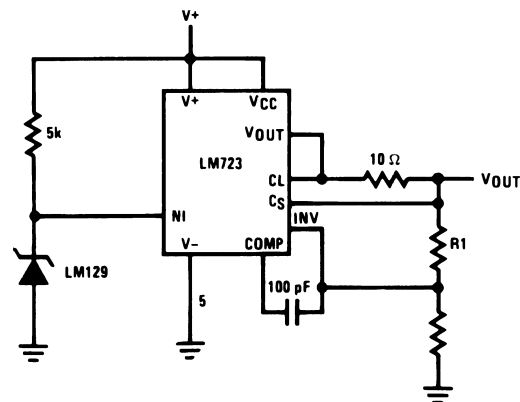

00561410

FIGURE 7. External Reference For IC

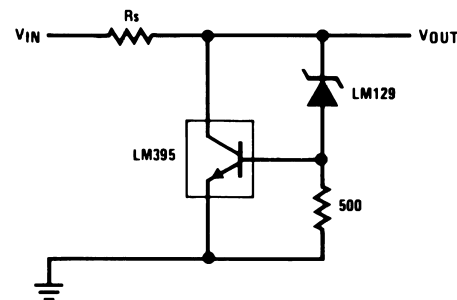

00561411

FIGURE 8. Power Shunt Regulator

Notes

LIFE SUPPORT POLICY

NATIONAL'S PRODUCTS ARE NOT AUTHORIZED FOR USE AS CRITICAL COMPONENTS IN LIFE SUPPORT DEVICES OR SYSTEMS WITHOUT THE EXPRESS WRITTEN APPROVAL OF THE PRESIDENT AND GENERAL COUNSEL OF NATIONAL SEMICONDUCTOR CORPORATION. As used herein:

1. Life support devices or systems are devices or systems which, (a) are intended for surgical implant into the body, or (b) support or sustain life, and whose failure to perform when properly used in accordance with instructions for use provided in the labeling, can be reasonably expected to result in a significant injury to the user.
2. A critical component is any component of a life support device or system whose failure to perform can be reasonably expected to cause the failure of the life support device or system, or to affect its safety or effectiveness.



National Semiconductor Corporation
Americas
Email: support@nsc.com

National Semiconductor Europe
Fax: +49 (0) 180-530 85 86
Email: europe.support@nsc.com
Deutsch Tel: +49 (0) 69 9508 6208
English Tel: +44 (0) 870 24 0 2171
Français Tel: +33 (0) 1 41 91 8790

National Semiconductor Asia Pacific Customer Response Group
Tel: 65-2544466
Fax: 65-2504466
Email: ap.support@nsc.com

National Semiconductor Japan Ltd.
Tel: 81-3-5639-7560
Fax: 81-3-5639-7507

www.national.com