

When designing or installing the cables for a video transmission system, one assumption commonly made is that the local earth grounds of both ends of the cable are the same. When circumstances don't support this assumption, the video performance can exhibit gross distortions. Therefore, the situations in which ground may have a non-zero potential are presented. In response, basic options for grounding connectivity are reviewed. Finally, a solution is presented that ensures quality video transmission even when any ground potential differences are present.

In a perfect world, a low-impedance ground connection serves as a reference for all electronic signals. This assumption is reasonable for systems with ground planes or even those with short, wired connections. When comparing the earth ground potential between houses in a subdivision, the difference is typically in the microvolt range. Within a building, the measurements are similar. However, in the top floor of a 50-story high-rise, the earth-ground connection has been measured 10V above the first floor.

A separate issue is the use of ground potential as a third terminal in power connections. Many buildings in the United States that predate current electrical codes do not have a local ground connection besides the cold water pipe. The situation in Asia is exacerbated and a multitude of sites lack ground references. With the absence of ground, all signals are floating with respect to a stable reference like earth ground.

Figure 1 illustrates this concept of a ground loop with a simple driver and receiver circuit. Of course, in the ideal situation, V_{ED} is zero volts and the earth-ground connections (EGND1 and EGND2) both equal zero volts. Since the driver and receiver enjoy a low-impedance connection to earth ground, R_1 and R_2 also equal zero in the ideal case. However, when potential differences exist, a loop of $V_1 + V_{ED} - V_2$ is formed between the references of the driver and receiver.

Sometimes you can't control all aspects of a system. In buildings with excessive height or age, one side of the transmission set may already exist—and be prohibitively difficult to reach or upgrade. Consider an example where the driver circuitry is isolated and floating with respect to earth ground 1 (R_1 approaches infinity). As referenced earlier, V_1 may be equal to 10V. Let's assume that V_{ED} is 1V for simplicity. If, out of habit, the receiver is installed with its reference (GND2) tied to earth ground (EGND2), there is a 9V common-mode error between GND1 and GND2. The input circuitry of the receiver is overwhelmed and the system is not operational. Instead, the receiver ground must also be left floating, to match the driver circuitry and avoid large offset errors.

For minimizing DC errors, the driver and receiver ground should be treated the same. Either both are tied to earth ground

or both are left floating. Common-mode signals with frequency are introduced through the antenna capabilities of the wires and the power supply circuitry, and require specific consideration to reduce their effect. Even with the use of differential signals, any difference in the ground reference between the driver and receiver results in a common-mode signal on each line of the received pair. Figure 2 presents a solution for a receiver with common-mode cancellation circuitry. For simplicity, composite video signals are assumed. (This technique works equally well for other transmission systems.)

Proper termination of each must be maintained with transmission lines. The twisted-pair transmission line connected at B+ and B- must be terminated in 100Ω to a common-mode point to prevent reflections of the differential signal. This is provided by the resistors, R_{29} and R_{30} . R_{45} provides a location for the common-mode voltage. All resistors in the schematic are 1% tolerance to guarantee common-mode rejection within 50mV for 5V common-mode signals on the line.

Equalization for the high frequency components of the differential signal are provided by C_7 and C_8 with R_{31} and R_{32} . However, it is crucial that these signals remain free from common-mode noise. Therefore, the outputs are not referenced to the local ground. Instead, they use the reference provided by an op amp circuit.

This reference is a common-mode compensation voltage created by summing the signals of the differential transmission lines. The sum cancels the differential component and doubles the common-mode contribution from each line. This signal is connected to the input of the op amp, an ISL55001.

Since DC signals are already reduced by matching the reference of the driver and receiver as discussed above, $10\mu\text{F}$ capacitors couple the input and output of the amplifier. Similar size capacitors are used for supply bypass. These values are large enough to compensate 60Hz signals. Larger capacitors (or multiple values in parallel) may be used at the designer's discretion.

The output of the summing amp returns the common-mode voltage on the output side of the receiver network (B_{OUT+} and B_{OUT-}). The $30\text{k}\Omega$ matched pair of resistors (R_{33} and R_{34}) connects the differential signal at B_{OUT+} and B_{OUT-} to the common-mode voltage. Basically, the circuit provides a common-mode signal so that the input signals referenced to GND2:

$$\begin{aligned} B+ &= V_{DIFF}/2 + V_{CM} \\ B- &= -V_{DIFF}/2 + V_{CM} \end{aligned} \quad (\text{EQ. 1})$$

Become:

$$\begin{aligned} B_{OUT+} &= V_{DIFF}/2 + V_{CM} - V_{CM_CREATED} = V_{DIFF}/2 \\ B_{OUT-} &= -V_{DIFF}/2 + V_{CM} - V_{CM_CREATED} = -V_{DIFF}/2 \end{aligned} \quad (\text{EQ. 2})$$

Application Note 1310

The quality of this common-mode removal is demonstrated in Figures 3 and 4. Figure 3 shows a 1V peak sine wave (in yellow) on B- to represent the differential signal. In this example, both nodes B+ and B- share a 2V peak common-mode signal (in pink).

Figure 4 shows the success of the circuit in Figure 2. The differential signal (in yellow) has not changed. The common-mode signal (in pink) is measured at B_{OUT-}, displaying the successful reduction of the common-mode signal by a factor

of 20. Complete removal is limited by delay mismatch in the passive network and the accuracy of the resistor values.

With the techniques discussed, ground loops are overcome and common-mode signals are removed to restore video transmission in long-distance or old-building applications. Simply put, the ground references of the driver and receiver must be identical. Secondly, the addition of common-mode cancellation circuitry preserves the quality of differential component video and ensures that the common-mode input range of the receiver is not exceeded.

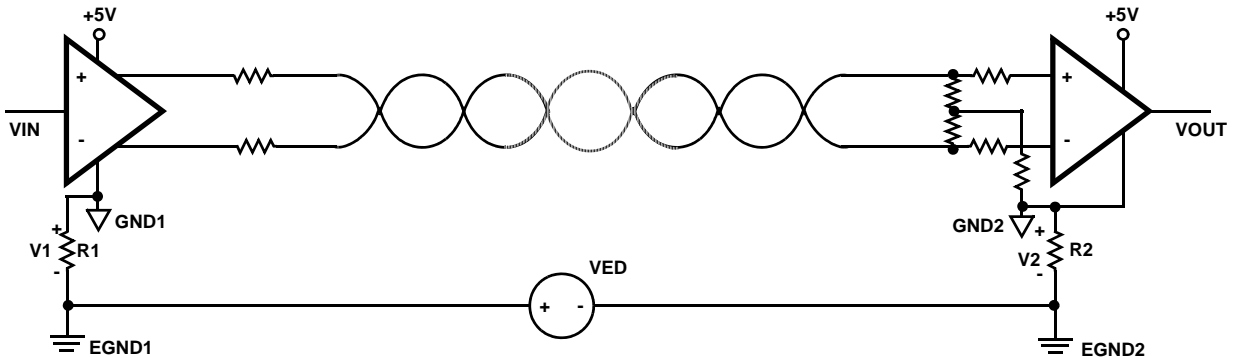

FIGURE 1. GROUND LOOP IN DIFFERENTIAL VIDEO TRANSMISSION SYSTEM

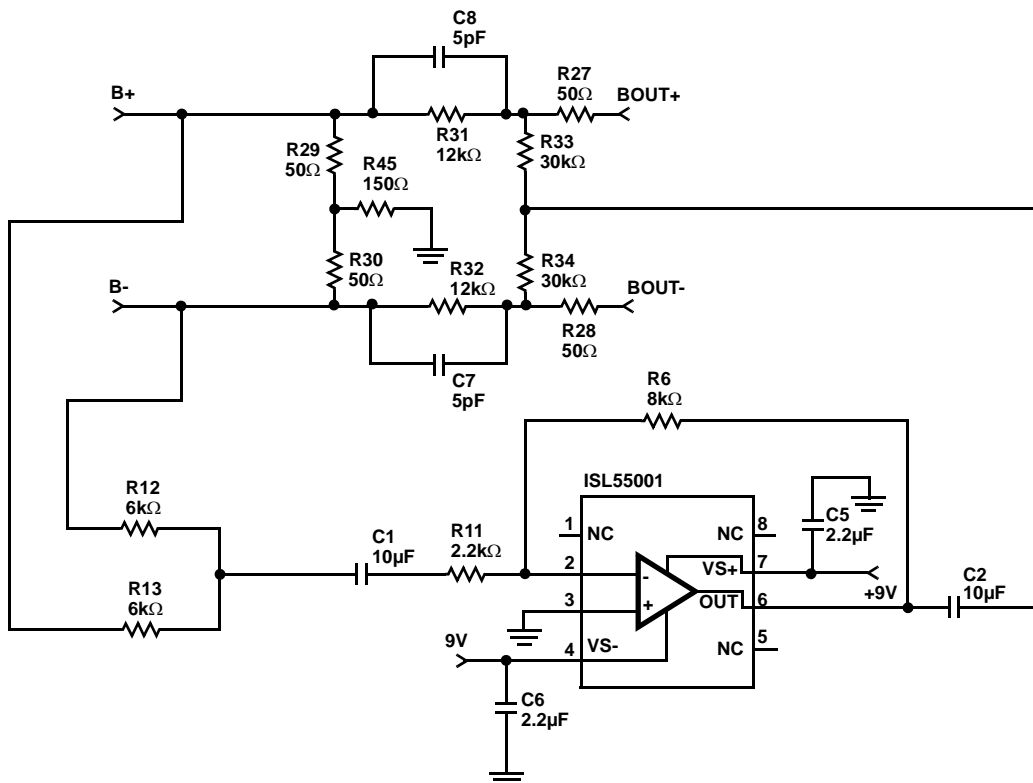

FIGURE 2. COMMON-MODE NOISE CANCELLATION CIRCUIT

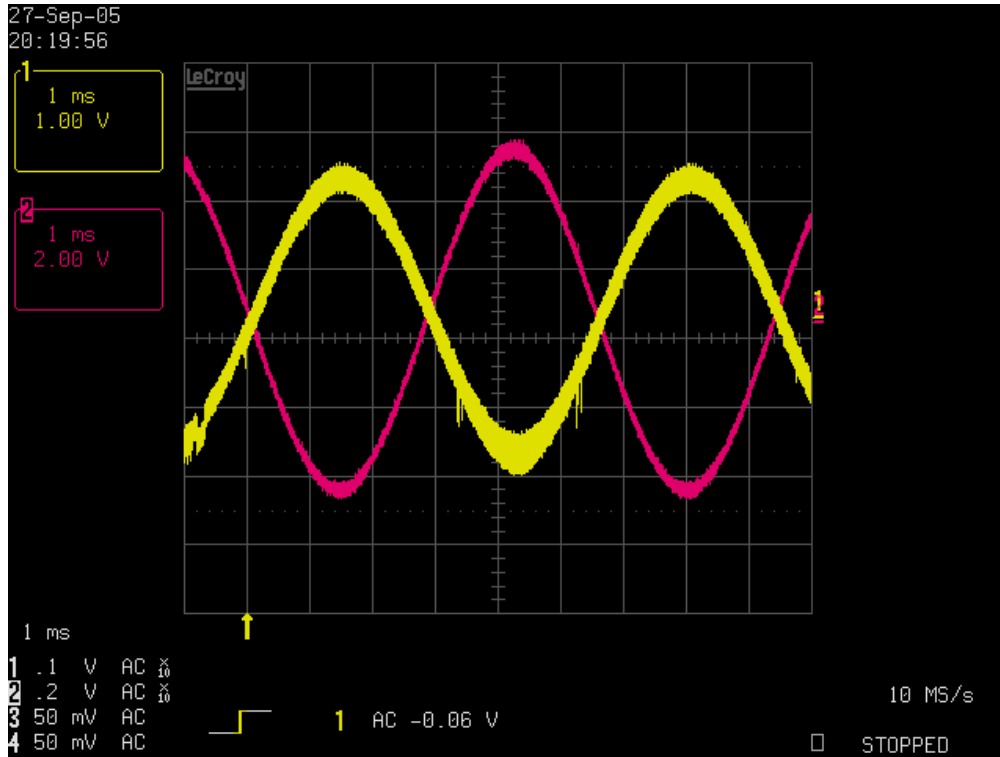

FIGURE 3. COMMON-MODE SIGNAL ON INPUT (YELLOW) AND FEEDBACK (PINK) LINES



FIGURE 4. COMMON-MODE SIGNAL IMPROVEMENT FROM INPUT (YELLOW) AND OUTPUT (PINK)

Intersil Corporation reserves the right to make changes in circuit design, software and/or specifications at any time without notice. Accordingly, the reader is cautioned to verify that the Application Note or Technical Brief is current before proceeding.

For information regarding Intersil Corporation and its products, see www.intersil.com