

3-Phase AC Induction Motor Vector Control Using a 56F80x, 56F8100 or 56F8300 Device

Design of Motor Control Application

Jaroslav Lepka, Petr Stekl

Note: The PC master software referenced in this document is also known as Free Master software.

1. Introduction

This application note describes the design of a 3-phase AC Induction Motor (ACIM) vector control drive with position encoder coupled to the motor shaft. It is based on Freescale's 56F80x and 56F8300 dedicated motor control devices. The software design takes advantage of Processor Expert™ (PE) software.

AC induction motors, which contain a cage, are very popular in variable-speed drives. They are simple, rugged, inexpensive and available at all power ratings. Progress in the field of power electronics and microelectronics enables the application of induction motors for high-performance drives, where traditionally only DC motors were applied. Thanks to sophisticated control methods, AC induction drives offer the same control capabilities as high performance four-quadrant DC drives.

This drive application allows vector control of the AC induction motor running in a closed-speed loop with the speed / position sensor coupled to the shaft. The application serves as an example of AC induction vector control drive design using a Freescale hybrid controller with PE support. It also illustrates the use of dedicated motor control libraries that are included in PE.

Contents

1. Introduction	1
2. Advantages and Features of Freescale's Hybrid Controller	2
2.1 56F805, 56800 Core Family	2
2.2 56F8346, 56800E Core Family	3
2.3 Peripheral Description	4
3. Target Motor Theory	6
3.1 AC Induction Motor	6
3.2 Mathematical Description of AC Induction Motors	8
3.3 Digital Control of an AC Induction Motor	13
4. Vector Control of AC Induction Machines	15
4.1 Block Diagram of the Vector Control ..	15
4.2 Forward and Inverse Clarke Transformation (a,b,c to α,β and backwards)	16
4.3 Forward and Inverse Park Transformation (α, β to d-q and backwards)	18
4.4 Rotor Flux Model	20
4.5 Decoupling Circuit	20
4.6 Space Vector Modulation	22
5. Design Concept of ACIM Vector Control Drives	25
5.1 System Outline	25
5.2 Application Description	26
6. Hardware Implementation	29
7. Software Implementation	31
7.1 Analog Value Scaling	31
7.2 Software Flowchart	34
7.3 Control Algorithm Data Flow	41
7.4 Application State Diagram	47
7.5 Speed Sensing	51
7.6 Analog Sensing	56
7.7 RUN / STOP Switch and Button Control	61
8. Processor Expert (PE) Implementation ..	63
8.1 Beans and Library Functions	63
8.2 Beans Initialization	64
8.3 Interrupts	64
8.4 PC Master Software	64
9. Hybrid Controller Use	66
10. References	67

This application note includes a description of Freescale hybrid controller features, basic AC induction motor theory, the system design concept, hardware implementation and software design, including the PC master software visualization tool.

2. Advantages and Features of Freescale's Hybrid Controller

The Freescale 56F80x (56800 core) and 56F8300 (56800E core) families are well-suited for digital motor control, combining the DSP's calculation capability with an MCU's controller features on a single chip. These hybrid controllers offer many dedicated peripherals, including a Pulse Width Modulation (PWM) unit, an Analog-to-Digital Converter (ADC), timers, communication peripherals (SCI, SPI, CAN), on-board Flash and RAM. Generally, all the family members are appropriate for use in AC induction motor control.

The following sections use a specific device to describe the family's features.

2.1 56F805, 56800 Core Family

The 56F805 provides the following peripheral blocks:

- Two Pulse Width Modulator units (PWMA and PWMB), each with six PWM outputs, three Current Sense inputs, and four Fault inputs, fault-tolerant design with dead time insertion; supports both center-aligned and edge-aligned modes
- 12-bit Analog-to-Digital Converters (ADCs), supporting two simultaneous conversions with dual 4-pin multiplexed inputs; ADC can be synchronized by PWM modules
- Two Quadrature Decoders (Quad Dec0 and Quad Dec1), each with four inputs, or two additional Quad Timers, A & B
- Two dedicated general purpose Quad Timers, totalling six pins: Timer C, with two pins and Timer D, with four pins
- CAN 2.0 B-compatible module with 2-pin ports used to transmit and receive
- Two Serial Communication Interfaces (SCI0 and SCI1), each with two pins, or four additional GPIO lines
- Serial Peripheral Interface (SPI), with a configurable 4-pin port (or four additional GPIO lines)
- Computer Operating Properly (COP) / Watchdog timer
- Two dedicated external interrupt pins
- 14 dedicated General Purpose I/O (GPIO) pins, 18 multiplexed GPIO pins
- External reset pin for hardware reset
- JTAG / On-Chip Emulation (OnCE) for unobtrusive, processor speed-independent debugging
- Software-programmable, Phase Lock Loop-based frequency synthesizer for the hybrid controller core clock

Table 2-1. Memory Configuration for 56F80x Devices

	56F801	56F803	56F805	56F807
Program Flash	8188 x 16-bit	32252 x 16-bit	32252 x 16-bit	61436 x 16-bit
Data Flash	2K x 16-bit	4K x 16-bit	4K x 16-bit	8K x 16-bit
Program RAM	1K x 16-bit	512 x 16-bit	512 x 16-bit	2K x 16-bit
Data RAM	1K x 16-bit	2K x 16-bit	2K x 16-bit	4K x 16-bit
Boot Flash	2K x 16-bit	2K x 16-bit	2K x16-bit	2K x 16-bit

2.2 56F8346, 56800E Core Family

The 56F8346 provides the following peripheral blocks:

- Two Pulse Width Modulator units (PWMA and PWMB), each with six PWM outputs, three Current Sense inputs, and three Fault inputs for PWMA/PWMB; fault-tolerant design with dead time insertion, supporting both center-aligned and edge-aligned modes
- Two, 12-bit Analog-to-Digital Converters (ADCs), supporting two simultaneous conversions with dual 4-pin multiplexed inputs; the ADC can be synchronized by PWM modules
- Two Quadrature Decoders (Quad Dec0 and Quad Dec1), each with four inputs, or two additional Quad Timers, A & B
- Two dedicated general purpose Quad Timers totaling three pins: Timer C, with one pin and Timer D, with two pins
- CAN 2.0 B-compatible module with 2-pin ports used to transmit and receive
- Two Serial Communication Interfaces (SCI0 and SCI1), each with two pins, or four additional GPIO lines
- Serial Peripheral Interface (SPI), with a configurable 4-pin port, or four additional GPIO lines
- Computer Operating Properly (COP) / Watchdog timer
- Two dedicated external interrupt pins
- 61 multiplexed General Purpose I/O (GPIO) pins
- External reset pin for hardware reset
- JTAG/On-Chip Emulation (OnCE)
- Software-programmable, Phase Lock Loop-based frequency synthesizer for the hybrid controller core clock
- Temperature Sensor system

Table 2-2. Memory Configuration for 56F8300 Devices

	56F8322	56F8323	56F8345	56F8346	56F8347
Program Flash	16K x 16 bit	16K x 16 bit	64K x 16-bit	64K x 16-bit	64 x 16-bit
Data Flash	4K x 16 bit	4K x 16 bit	4K x 16-bit	4K x 16-bit	4K x 16-bit
Program RAM	2K x 16 bit	2K x 16 bit	2K x 16-bit	2K x 16-bit	2K x 16-bit
Data RAM	4K x 16 bit	4K x 16 bit	4K x 16-bit	4K x 16-bit	2K x 16-bit
Boot Flash	4K x 16 bit	4K x 16 bit	4K x 16-bit	4K x 16-bit	4K x 16-bit

Memory Configuration for 56F8300 Devices

	56F8355	56F8356	56F8357	56F8365	56F8366	56F8367
Program Flash	128K x 16-bit	128K x 16-bit	128K x 16-bit	256K x 16-bit	128K x 16-bit	128K x 16-bit
Data Flash	4K x 16-bit	4K x 16-bit	4K x 16-bit	16K x 16-bit	4K x 16-bit	4K x 16-bit
Program RAM	2K x 16-bit	2K x 16-bit	2K x 16-bit	2K x 16-bit	2K x 16-bit	2K x 16-bit
Data RAM	8K x 16-bit	8K x 16-bit	8K x 16-bit	16K x 16-bit	4K x 16-bit	8K x 16-bit
Boot Flash	4K x 16-bit	8K x 16-bit	8K x 16-bit	16K x 16-bit	8K x 16-bit	8K x 16-bit

2.3 Peripheral Description

PWM modules are the hybrid controller's key features enabling motor control. The device is designed to control most motor types, including induction motors. An interesting feature for controlling the AC induction motor at low speeds is the patented PWM waveform distortion correction circuit. Each PWM is double-buffered and includes interrupt controls. The PWM module provides a reference output to synchronize the Analog-to-Digital Converters.

The PWM has the following features:

- Three complementary PWM signal pairs, or six independent PWM signals
- Features of complementary channel operation
- Dead time insertion
- Separate top and bottom pulse width correction via current status inputs or software
- Separate top and bottom polarity control
- Edge-aligned or center-aligned PWM signals
- Resolution of 15 bits
- Half-cycle reload capability
- Integral reload rates from 1 to 16

- Individual software-controlled PWM outputs
- Mask and swap of PWM outputs
- Programmable fault protection
- Polarity control
- 20mA current sink capability on PWM pins
- Write-protectable registers

The AC induction motor control utilizes the PWM block set in the complementary PWM mode, permitting generation of control signals for all switches of the power stage with inserted dead time. The PWM block generates three sinewave outputs mutually shifted by 120 degrees.

The Analog-to-Digital Converter (ADC) consists of a digital control module and two analog Sample and Hold (S/H) circuits. ADC features:

- 12-bit resolution
- Maximum ADC clock frequency is 5MHz with 200ns period
- Single conversion time of 8.5 ADC clock cycles ($8.5 \times 200\text{ns} = 1.7\mu\text{s}$)
- Additional conversion time of 6 ADC clock cycles ($6 \times 200\text{ns} = 1.2\mu\text{s}$)
- Eight conversions in 26.5 ADC clock cycles ($26.5 \times 200\text{ns} = 5.3\mu\text{s}$) using simultaneous mode
- ADC can be synchronized to the PWM via the sync signal
- Simultaneous or sequential sampling
- Internal multiplexer to select two of eight inputs
- Ability to sequentially scan and store up to eight measurements
- Ability to simultaneously sample and hold two inputs
- Optional interrupts at end of scan, if an out-of-range limit is exceeded, or at zero crossing
- Optional sample correction by subtracting a preprogrammed offset value
- Signed or unsigned result
- Single-ended or differential inputs

The application utilizes the ADC block in simultaneous mode and sequential scan. It is synchronized with PWM pulses. This configuration allows the simultaneous conversion within the required time of required analog values, of all phase currents, voltage and temperature.

The Quad Timer is an extremely flexible module, providing all required services relating to time events. It has the following features:

- Each timer module consists of four 16-bit counters / timers
- Counts up / down
- Counters are cascadable
- Programmable count modulo
- Maximum count rate equals peripheral clock/2 when counting external events
- Maximum count rate equals peripheral clock when using internal clocks
- Counts once or repeatedly
- Counters are preloadable
- Counters can share available input pins

- Each counter has a separate prescaler
- Each counter has capture and compare capability

The AC induction motor vector control application utilizes four channels of the Quad Timer module for position and speed sensing. A fifth channel of the Quad Timer module is set to generate a time base for speed sensing and a speed controller.

The Quadrature Decoder is a module providing decoding of position signals from a Quadrature Encoder mounted on a motor shaft. It has the following features:

- Includes logic to decode quadrature signals
- Configurable digital filter for inputs
- 32-bit position counter
- 16-bit position difference counter
- Maximum count frequency equals the peripheral clock rate
- Position counter can be initialized by software or external events
- Preloadable 16-bit revolution counter
- Inputs can be connected to a general purpose timer to aid low speed velocity.

The AC induction motor vector control application utilizes the Quadrature Decoder connected to Quad Timer module B. It uses the decoder's digital input filter to filter the encoder's signals, but does not make use of its decoding functions, freeing the decoder's digital processing capabilities to be used by another application.

3. Target Motor Theory

3.1 AC Induction Motor

The AC induction motor is a rotating electric machine designed to operate from a 3-phase source of alternating voltage. For variable speed drives, the source is normally an inverter that uses power switches to produce approximately sinusoidal voltages and currents of controllable magnitude and frequency.

A cross-section of a two-pole induction motor is shown in [Figure 3-1](#). Slots in the inner periphery of the stator accommodate 3-phase winding a,b,c. The turns in each winding are distributed so that a current in a stator winding produces an approximately sinusoidally-distributed flux density around the periphery of the air gap. When three currents that are sinusoidally varying in time, but displaced in phase by 120° from each other, flow through the three symmetrically-placed windings, a radially-directed air gap flux density is produced that is also sinusoidally distributed around the gap and rotates at an angular velocity equal to the angular frequency, ω_s , of the stator currents.

The most common type of induction motor has a squirrel cage rotor in which aluminum conductors or bars are cast into slots in the outer periphery of the rotor. These conductors or bars are shorted together at both ends of the rotor by cast aluminum end rings, which also can be shaped to act as fans. In larger induction motors, copper or copper-alloy bars are used to fabricate the rotor cage winding.

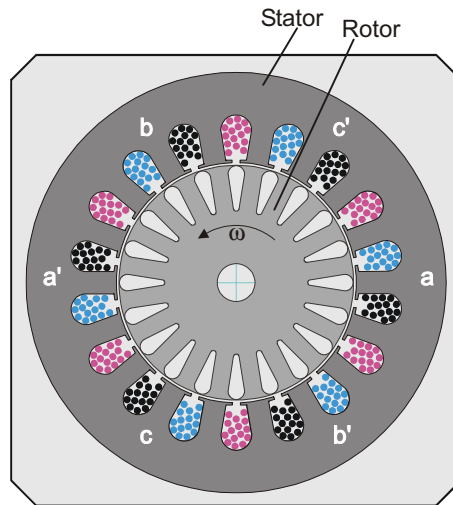

Figure 3-1. 3-Phase AC Induction Motor

As the sinusoidally-distributed flux density wave produced by the stator magnetizing currents sweeps past the rotor conductors, it generates a voltage in them. The result is a sinusoidally-distributed set of currents in the short-circuited rotor bars. Because of the low resistance of these shorted bars, only a small relative angular velocity, ω_r , between the angular velocity, ω_s , of the flux wave and the mechanical angular velocity ω of the two-pole rotor is required to produce the necessary rotor current. The relative angular velocity, ω_r , is called the slip velocity. The interaction of the sinusoidally-distributed air gap flux density and induced rotor currents produces a torque on the rotor. The typical induction motor speed-torque characteristic is shown in [Figure 3-2](#).

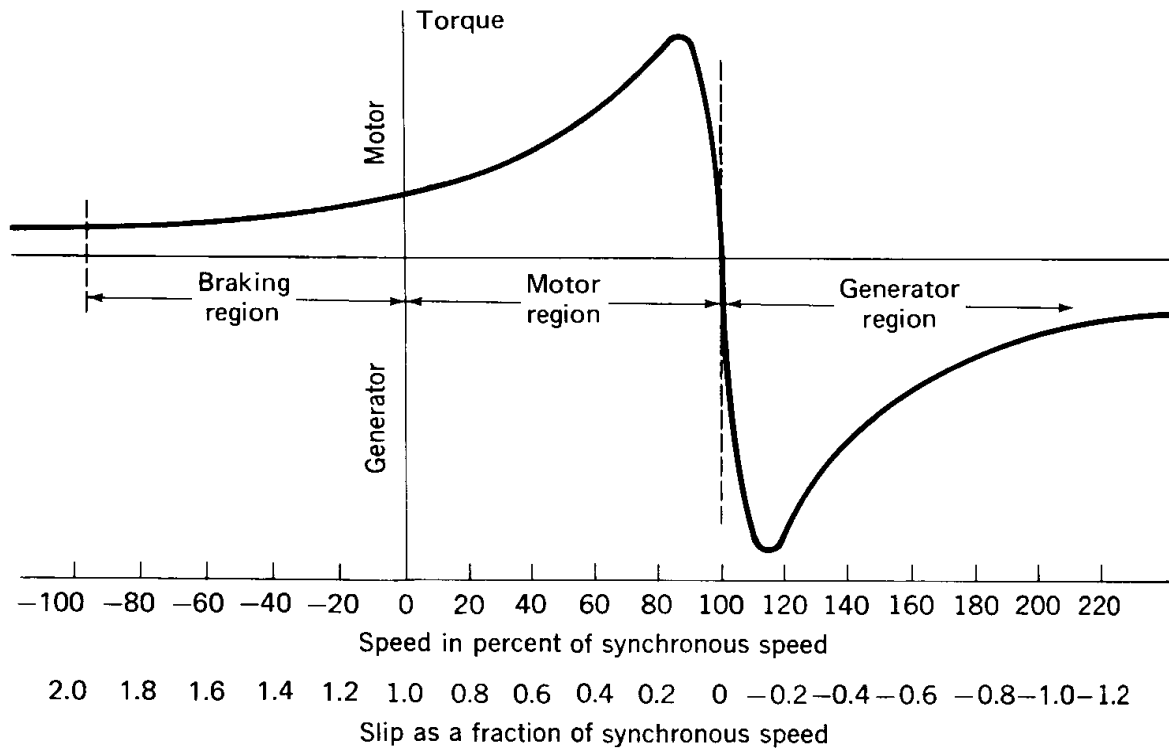

Figure 3-2. AC Induction Motor Speed-Torque Characteristic

Squirrel-cage AC induction motors are popular for their simple construction, low cost per horsepower, and low maintenance (they contain no brushes, as do DC motors). They are available in a wide range of power ratings. With field-oriented vector control methods, AC induction motors can fully replace standard DC motors, even in high-performance applications.

3.2 Mathematical Description of AC Induction Motors

There are a number of AC induction motor models. The model used for vector control design can be obtained by using the space vector theory. The 3-phase motor quantities (such as voltages, currents, magnetic flux, etc.) are expressed in terms of complex space vectors. Such a model is valid for any instantaneous variation of voltage and current and adequately describes the performance of the machine under both steady-state and transient operation. Complex space vectors can be described using only two orthogonal axes. The motor can be considered a 2-phase machine. The utilization of the 2-phase motor model reduces the number of equations and simplifies the control design.

3.2.1 Space Vector Definition

Assume that i_{sa} , i_{sb} , and i_{sc} are the instantaneous balanced 3-phase stator currents:

$$i_{sa} + i_{sb} + i_{sc} = 0 \quad \text{EQ. 3-1}$$

The stator current space vector can then be defined as follows:

$$\bar{i}_s = k(i_{sa} + ai_{sb} + a^2i_{sc}) \quad \text{EQ. 3-2}$$

Where:

a and a^2 = The spatial operators, $a = e^{j2\pi/3}$, $a^2 = e^{j4\pi/3}$

k = The transformation constant and is chosen $k=2/3$

Figure 3-3 shows the stator current space vector projection:

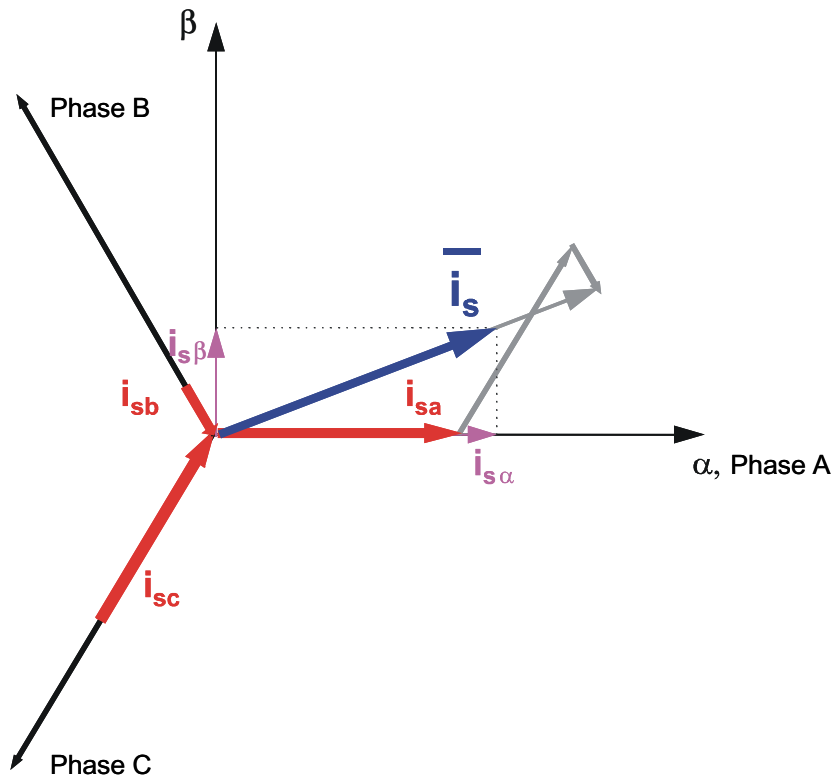

Figure 3-3. Stator Current Space Vector and Its Projection

The space vector defined by **EQ. 3-2** can be expressed utilizing the two-axis theory. The real part of the space vector is equal to the instantaneous value of the direct-axis stator current component, $i_{s\alpha}$, and whose imaginary part is equal to the quadrature-axis stator current component, $i_{s\beta}$. Thus, the stator current space vector in the stationary reference frame attached to the stator can be expressed as:

$$\bar{i}_s = i_{s\alpha} + ji_{s\beta} \quad \text{EQ. 3-3}$$

In symmetrical 3-phase machines, the direct and quadrature axis stator currents $i_{s\alpha}$, $i_{s\beta}$ are fictitious quadrature-phase (2-phase) current components, which are related to the actual 3-phase stator currents as follows:

$$i_{s\alpha} = k \left(i_{sa} - \frac{1}{2} i_{sb} - \frac{1}{2} i_{sc} \right) \quad \text{EQ. 3-4}$$

$$i_{s\beta} = k \frac{\sqrt{3}}{2} (i_{sb} - i_{sc}) \quad \text{EQ. 3-5}$$

Where:

$k=2/3$ is a transformation constant

The space vectors of other motor quantities (voltages, currents, magnetic fluxes, etc.) can be defined in the same way as the stator current space vector.

3.2.2 AC Induction Motor Model

The AC induction motor model is given by the space vector form of the voltage equations. The system model defined in the stationary α, β -coordinate system attached to the stator is expressed by the following equations. Ideally, the motor model is symmetrical, with a linear magnetic circuit characteristic.

- a. The stator voltage differential equations:

$$u_{s\alpha} = R_s i_{s\alpha} + \frac{d}{dt} \Psi_{s\alpha} \quad \text{EQ. 3-6}$$

$$u_{s\beta} = R_s i_{s\beta} + \frac{d}{dt} \Psi_{s\beta} \quad \text{EQ. 3-7}$$

- b. The rotor voltage differential equations:

$$u_{r\alpha} = 0 = R_r i_{r\alpha} + \frac{d}{dt} \Psi_{r\alpha} + \omega \Psi_{r\beta} \quad \text{EQ. 3-8}$$

$$u_{r\beta} = 0 = R_r i_{r\beta} + \frac{d}{dt} \Psi_{r\beta} - \omega \Psi_{r\alpha} \quad \text{EQ. 3-9}$$

- c. The stator and rotor flux linkages expressed in terms of the stator and rotor current space vectors:

$$\Psi_{s\alpha} = L_s i_{s\alpha} + L_m i_{r\alpha} \quad \text{EQ. 3-10}$$

$$\Psi_{s\beta} = L_s i_{s\beta} + L_m i_{r\beta} \quad \text{EQ. 3-11}$$

$$\Psi_{r\alpha} = L_r i_{r\alpha} + L_m i_{s\alpha} \quad \text{EQ. 3-12}$$

$$\Psi_{r\beta} = L_r i_{r\beta} + L_m i_{s\beta} \quad \text{EQ. 3-13}$$

d. Electromagnetic torque expressed by utilizing space vector quantities:

$$t_e = \frac{3}{2} p_p (\Psi_{s\alpha} i_{s\beta} - \Psi_{s\beta} i_{s\alpha}) \quad \text{EQ. 3-14}$$

where:

α, β	= Stator orthogonal coordinate system
$u_{s\alpha, \beta}$	= Stator voltages [V]
$i_{s\alpha, \beta}$	= Stator currents [A]
$u_{r\alpha, \beta}$	= Rotor voltages [V]
$i_{r\alpha, \beta}$	= Rotor currents [A]
$\Psi_{s\alpha, \beta}$	= Stator magnetic fluxes [Vs]
$\Psi_{r\alpha, \beta}$	= Rotor magnetic fluxes [Vs]
R_s	= Stator phase resistance [Ohm]
R_r	= Rotor phase resistance [Ohm]
L_s	= Stator phase inductance [H]
L_r	= Rotor phase inductance [H]
L_m	= Mutual (stator to rotor) inductance [H]
ω / ω_s	= Electrical rotor speed / synchronous speed [rad/s]
p_p	= Number of pole pairs [-]
t_e	= electromagnetic torque [Nm]

Besides the stationary reference frame attached to the stator, motor model voltage space vector equations can be formulated in a general reference frame, which rotates at a general speed, ω_g . If a general reference frame, with direct and quadrature axes x, y rotating at a general instantaneous speed $\omega_g = d\theta_g/dt$ is used, as shown in [Figure 3-4](#), where θ_g is the angle between the direct axis of the stationary reference frame (α) attached to the stator and the real axis (x) of the general reference frame, then the following equation defines the stator current space vector in general reference frame:

$$\overline{i_{sg}} = \overline{i_s} e^{-j\theta_g} = i_{sx} + j i_{sy} \quad \text{EQ. 3-15}$$

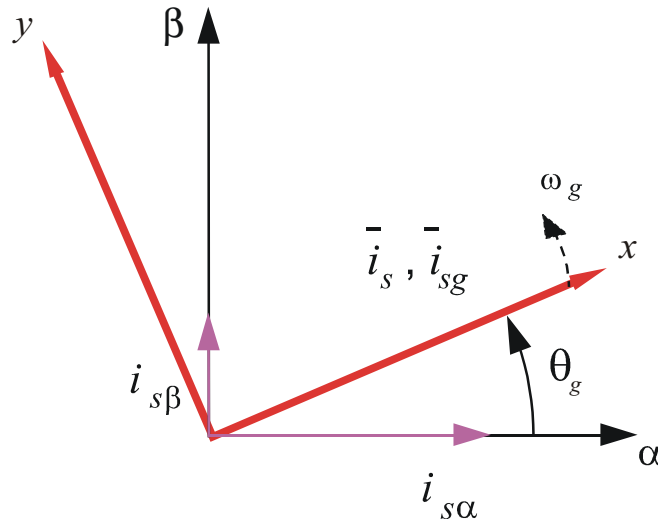

Figure 3-4. Application of the General Reference Frame

The stator voltage and flux-linkage space vectors can be similarly obtained in the general reference frame.

Similar considerations hold for the space vectors of the rotor voltages, currents and flux linkages. The real axis ($r\alpha$) of the reference frame attached to the rotor is displaced from the direct axis of the stator reference frame by the rotor angle, θ_r . As shown, the angle between the real axis (x) of the general reference frame and the real axis of the reference frame rotating with the rotor ($r\alpha$) is $\theta_g - \theta_r$. In the general reference frame, the space vector of the rotor currents can be expressed as:

$$\bar{i}_{rg} = \bar{i}_r e^{-j(\theta_g - \theta_r)} = i_{rx} + j i_{ry} \quad \text{EQ. 3-16}$$

Where:

\bar{i}_r = The space vector of the rotor current in the rotor reference frame

The space vectors of the rotor voltages and rotor flux linkages in the general reference frame can be expressed similarly.

The motor model voltage equations in the general reference frame can be expressed by using the transformations of the motor quantities from one reference frame to the general reference frame introduced. The AC induction motor model is often used in vector control algorithms. The aim of vector control is to implement control schemes which produce high-dynamic performance and are similar to those used to control DC machines. To achieve this, the reference frames may be aligned with the stator flux-linkage space vector,

the rotor flux-linkage space vector or the magnetizing space vector. The most popular reference frame is the reference frame attached to the rotor flux linkage space vector with direct axis (d) and quadrature axis (q). After transformation into d- q coordinates the motor model follows:

$$u_{sd} = R_s i_{sd} + \frac{d}{dt} \Psi_{sd} - \omega_s \Psi_{sq} \quad \text{EQ. 3-17}$$

$$u_{sq} = R_s i_{sq} + \frac{d}{dt} \Psi_{sq} + \omega_s \Psi_{sd} \quad \text{EQ. 3-18}$$

$$u_{rd} = 0 = R_r i_{rd} + \frac{d}{dt} \Psi_{rd} - (\omega_s - \omega) \Psi_{rq} \quad \text{EQ. 3-19}$$

$$u_{rq} = 0 = R_r i_{rq} + \frac{d}{dt} \Psi_{rq} + (\omega_s - \omega) \Psi_{rd} \quad \text{EQ. 3-20}$$

$$\Psi_{sd} = L_s i_{sd} + L_m i_{rd} \quad \text{EQ. 3-21}$$

$$\Psi_{sq} = L_s i_{sq} + L_m i_{rq} \quad \text{EQ. 3-22}$$

$$\Psi_{rd} = L_r i_{rd} + L_m i_{sd} \quad \text{EQ. 3-23}$$

$$\Psi_{rq} = L_r i_{rq} + L_m i_{sq} \quad \text{EQ. 3-24}$$

$$t_e = \frac{3}{2} p_p (\Psi_{sd} i_{sq} - \Psi_{sq} i_{sd}) \quad \text{EQ. 3-25}$$

3.3 Digital Control of an AC Induction Motor

In adjustable-speed applications, AC motors are powered by inverters. The inverter converts DC power to AC power at the required frequency and amplitude.

Figure 3-5 illustrates a typical 3-phase inverter.

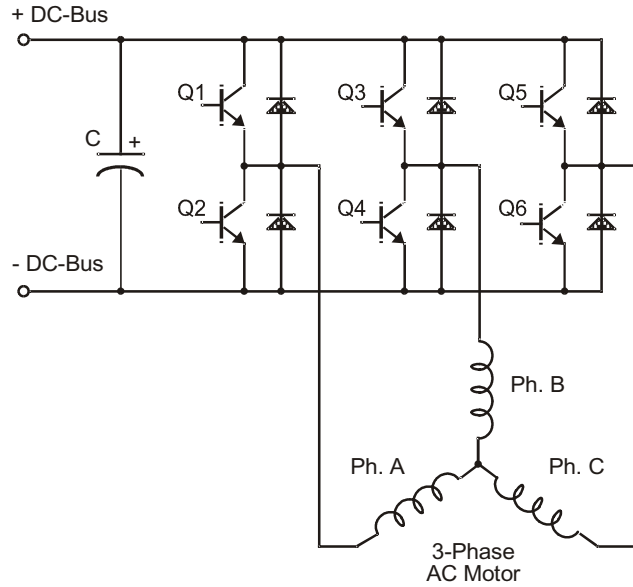

Figure 3-5. 3-Phase Inverter

The inverter consists of three half-bridge units where the upper and lower switch are controlled complementarily, meaning when the upper one is turned on, the lower one must be turned off, and vice versa. As the power device’s turn-off time is longer than its turn-on time, some dead time must be inserted between the time one transistor of the half-bridge is turned off and its complementary device is turned on. The output voltage is mostly created by a Pulse Width Modulation (PWM) technique, where an isosceles triangle carrier wave is compared with a fundamental-frequency sine modulating wave. The natural points of intersection determine the switching points of the power devices of a half-bridge inverter. This technique is shown in [Figure 3-6](#). The 3-phase voltage waves are shifted 120° to one another and thus a 3-phase motor can be supplied

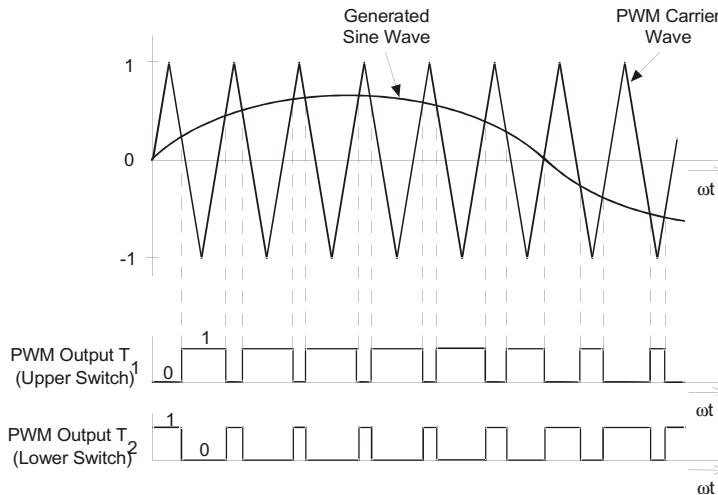

Figure 3-6. Pulse Width Modulation

The most popular power devices for motor control applications are Power MOSFETs and IGBTs.

A Power MOSFET is a voltage-controlled transistor. It is designed for high-frequency operation and has a low-voltage drop, so it has low power losses. However, saturation temperature sensitivity limits the MOSFET's use in high-power applications.

An Insulated-Gate Bipolar Transistor (IGBT) is controlled by a MOSFET on its base. The IGBT requires low drive current, has fast switching time, and is suitable for high switching frequencies. The disadvantage is the higher voltage drop of the bipolar transistor, causing higher conduction losses.

4. Vector Control of AC Induction Machines

Vector control is the most popular control technique of AC induction motors. In special reference frames, the expression for the electromagnetic torque of the smooth-air-gap machine is similar to the expression for the torque of the separately excited DC machine. In the case of induction machines, the control is usually performed in the reference frame (d-q) attached to the rotor flux space vector. That's why the implementation of vector control requires information on the modulus and the space angle (position) of the rotor flux space vector. The stator currents of the induction machine are separated into flux- and torque-producing components by utilizing transformation to the d-q coordinate system, whose direct axis (*d*) is aligned with the rotor flux space vector. That means that the *q*-axis component of the rotor flux space vector is always zero:

$$\Psi_{rq} = 0 \text{ and } \frac{d}{dt}\Psi_{rq} = 0 \quad \text{EQ. 4-1}$$

The rotor flux space vector calculation and transformation to the d-q coordinate system require the high computational power of a microcontroller; a digital signal processor is suitable for this task. The following sections describe the space vector transformations and the rotor flux space vector calculation.

4.1 Block Diagram of the Vector Control

Figure 4-1 shows the basic structure of the vector control of the AC induction motor. To perform vector control, follow these steps:

- Measure the motor quantities (phase voltages and currents)
- Transform them to the 2-phase system (α, β) using a Clarke transformation
- Calculate the rotor flux space vector magnitude and position angle
- Transform stator currents to the d-q coordinate system using a Park transformation
- The stator current torque- (i_{sq}) and flux- (i_{sd}) producing components are separately controlled
- The output stator voltage space vector is calculated using the decoupling block
- An inverse Park transformation transforms the stator voltage space vector back from the d-q coordinate system to the 2-phase system fixed with the stator
- Using the space vector modulation, the output 3-phase voltage is generated

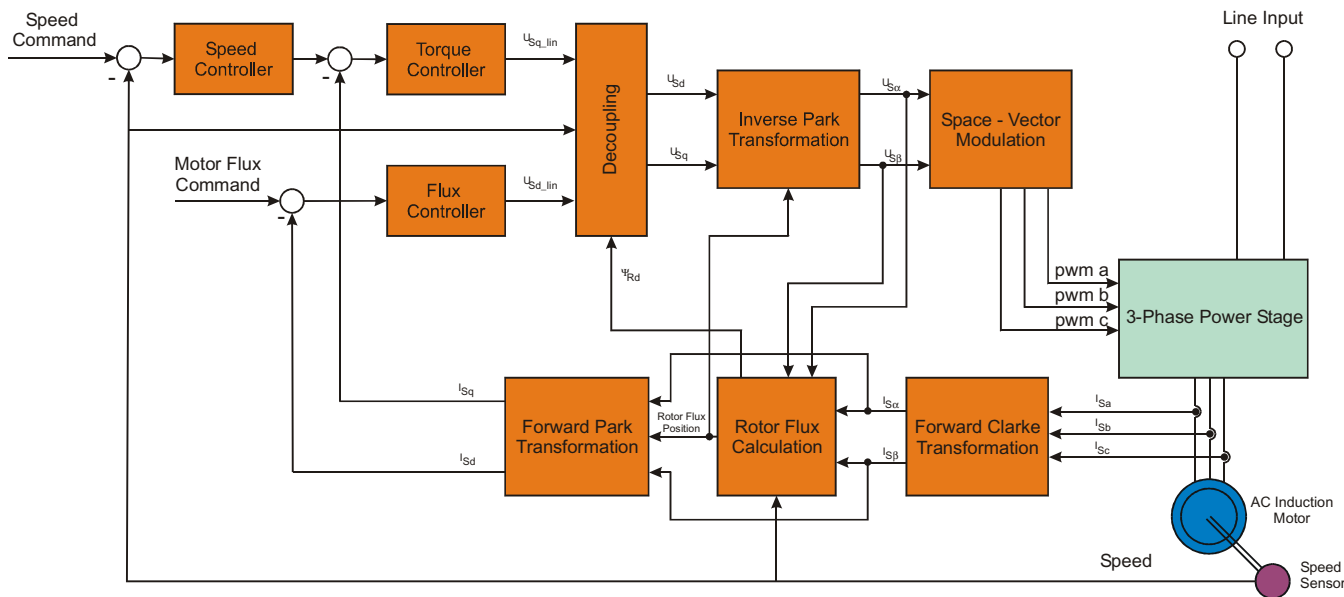

Figure 4-1. Block Diagram of the AC Induction Motor Vector Control

4.2 Forward and Inverse Clarke Transformation (a,b,c to α,β and backwards)

The forward Clarke transformation converts a 3-phase system (a, b, c) to a 2-phase coordinate system (α, β). **Figure 4-2** shows graphical construction of the space vector and projection of the space vector to the quadrature-phase components α, β .

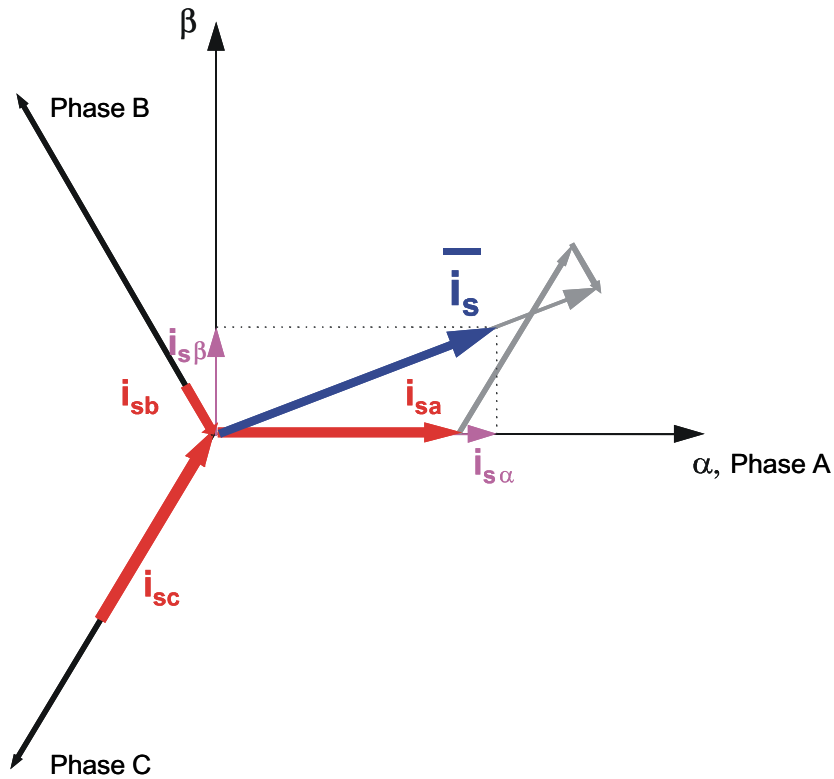

Figure 4-2. Clarke Transformation

Assuming that the a axis and the α axis are in the same direction, the quadrature-phase stator currents $i_{s\alpha}$ and $i_{s\beta}$ are related to the actual 3-phase stator currents as follows:

$$i_{s\alpha} = k \left[i_{sa} - \frac{1}{2}i_{sb} - \frac{1}{2}i_{sc} \right]$$

$$i_{s\beta} = k \frac{\sqrt{3}}{2} (i_{sb} - i_{sc})$$

EQ. 4-2

where:

i_{sa} = Actual current of the motor Phase A [A]

i_{sb} = Actual current of the motor Phase B [A]

$i_{s\alpha,\beta}$ = Actual current of the motor Phase C [A]

The constant k equals $k = 2/3$ for the non-power-invariant transformation. In this case, the quantities i_{sa} and $i_{s\alpha}$ are equal. If it's assumed that $i_{sa} + i_{sb} + i_{sc} = 0$, the quadrature-phase components can be expressed utilizing only two phases of the 3-phase system:

$$\begin{aligned} i_{s\alpha} &= i_{sa} \\ i_{s\beta} &= \frac{1}{\sqrt{3}}i_{sa} + \frac{2}{\sqrt{3}}i_{sb} \end{aligned} \quad \text{EQ. 4-3}$$

The inverse Clarke transformation goes from a 2-phase (α , β) to a 3-phase i_{sa} , i_{sb} , i_{sc} system. For constant $k = 2/3$, it is calculated by the following equations:

$$\begin{aligned} i_{sa} &= i_{s\alpha} \\ i_{sb} &= -\frac{1}{2}i_{s\alpha} + \frac{\sqrt{3}}{2}i_{s\beta} \\ i_{sc} &= -\frac{1}{2}i_{s\alpha} - \frac{\sqrt{3}}{2}i_{s\beta} \end{aligned} \quad \text{EQ. 4-4}$$

4.3 Forward and Inverse Park Transformation (α , β to d-q and backwards)

The components $i_{s\alpha}$ and $i_{s\beta}$, calculated with a Clarke transformation, are attached to the stator reference frame α , β . In vector control, all quantities must be expressed in the same reference frame. The stator reference frame is not suitable for the control process. The space vector \vec{i}_s is rotating at a rate equal to the angular frequency of the phase currents. The components $i_{s\alpha}$ and $i_{s\beta}$ depend on time and speed. These components can be transformed from the stator reference frame to the d-q reference frame rotating at the same speed as the angular frequency of the phase currents. The i_{sd} and i_{sq} components do not then depend on time and speed. If the d -axis is aligned with the rotor flux, the transformation is illustrated in [Figure 4-3](#), where θ_{Field} is the rotor flux position.

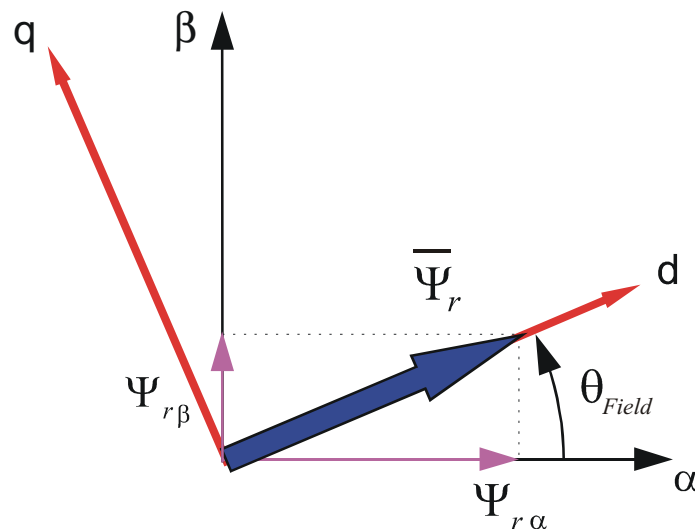

Figure 4-3. Park Transformation

The components i_{sd} and i_{sq} of the current space vector in the d-q reference frame are determined by the following equations:

$$\begin{aligned} i_{sd} &= i_{s\alpha} \cos\theta_{Field} + i_{s\beta} \sin\theta_{Field} \\ i_{sq} &= -i_{s\alpha} \sin\theta_{Field} + i_{s\beta} \cos\theta_{Field} \end{aligned} \quad \text{EQ. 4-5}$$

The component i_{sd} is called the **direct axis component (the flux-producing component)** and i_{sq} is called the **quadrature axis component (the torque-producing component)**. They are time invariant; flux and torque control with them is easy. To avoid using trigonometric functions on the hybrid controller, directly calculate $\sin\theta_{Field}$ and $\cos\theta_{Field}$ using division, defined by the following equations:

$$\Psi_{rd} = \sqrt{\Psi_{r\alpha}^2 + \Psi_{r\beta}^2} \quad \text{EQ. 4-6}$$

$$\begin{aligned} \sin\theta_{Field} &= \frac{\Psi_{r\beta}}{\Psi_{rd}} \\ \cos\theta_{Field} &= \frac{\Psi_{r\alpha}}{\Psi_{rd}} \end{aligned} \quad \text{EQ. 4-7}$$

The inverse Park transformation from the d-q to the α , β coordinate system is found by the following equations:

$$\begin{aligned} i_{s\alpha} &= i_{sd} \cos\theta_{Field} - i_{sq} \sin\theta_{Field} \\ i_{s\beta} &= i_{sd} \sin\theta_{Field} + i_{sq} \cos\theta_{Field} \end{aligned} \quad \text{EQ. 4-8}$$

4.4 Rotor Flux Model

Knowledge of the rotor flux space vector magnitude and position is key information for AC induction motor vector control. With the rotor magnetic flux space vector, the rotational coordinate system (d-q) can be established. There are several methods for obtaining the rotor magnetic flux space vector. The flux model implemented here utilizes monitored rotor speed and stator voltages and currents. It is calculated in the stationary reference frame (α , β) attached to the stator. The error in the calculated value of the rotor flux, influenced by the changes in temperature, is negligible for this rotor flux model.

The rotor flux space vector is obtained by solving the differential equations [EQ. 4-2](#) and [EQ. 4-3](#), which are resolved into the α and β components. The equations are derived from the equations of the AC induction motor model; see [Section 3.2.2](#).

$$[(1 - \sigma)T_s + T_r] \frac{d\Psi_{r\alpha}}{dt} = \frac{L_m}{R_s} u_{s\alpha} - \Psi_{r\alpha} - \omega T_r \Psi_{r\beta} - \sigma L_m T_s \frac{di_{s\alpha}}{dt} \quad \text{EQ. 4-9}$$

$$[(1 - \sigma)T_s + T_r] \frac{d\Psi_{r\beta}}{dt} = \frac{L_m}{R_s} u_{s\beta} + \omega T_r \Psi_{r\alpha} - \Psi_{r\beta} - \sigma L_m T_s \frac{di_{s\beta}}{dt} \quad \text{EQ. 4-10}$$

Where:

$$\begin{aligned}
 L_s &= \text{Self-inductance of the stator [H]} \\
 L_r &= \text{Self-inductance of the rotor [H]} \\
 L_m &= \text{Magnetizing inductance [H]} \\
 R_r &= \text{Resistance of a rotor phase winding [Ohm]} \\
 R_s &= \text{Resistance of a stator phase winding [Ohm]} \\
 \omega &= \text{Angular rotor speed [rad.s}^{-1}\text{]} \\
 p_p &= \text{Number of motor pole pairs} \\
 T_r &= \frac{L_r}{R_r} = \text{Rotor time constant [s]} \\
 T_s &= \frac{L_s}{R_s} = \text{Stator time constant [s]} \\
 \sigma &= 1 - \frac{L_m^2}{L_s L_r} = \text{Resultant leakage constant [-]}
 \end{aligned}$$

The α , β components of the stator voltage, currents and rotor flux space vectors are $u_{s\alpha}$, $u_{s\beta}$, $i_{s\alpha}$, $i_{s\beta}$, $\Psi_{r\alpha}$, $\Psi_{r\beta}$.

4.5 Decoupling Circuit

For purposes of the rotor flux-oriented vector control, the direct-axis stator current i_{sd} (the rotor flux-producing component) and the quadrature-axis stator current i_{sq} (the torque-producing component) must be controlled independently. However, the equations of the stator voltage components are coupled. The direct axis component u_{sd} also depends on i_{sq} and the quadrature axis component u_{sq} also depends on i_{sd} . The stator voltage components u_{sd} and u_{sq} cannot be considered as decoupled control variables for the rotor flux and electromagnetic torque. The stator currents i_{sd} and i_{sq} can only be independently controlled (decoupled control) if the stator voltage equations are decoupled and the stator current components i_{sd} and i_{sq} are indirectly controlled by controlling the terminal voltages of the induction motor.

The equations of the stator voltage components in the d-q coordinate system [EQ. 3-22](#) and [EQ. 3-23](#) can be reformulated and separated into two components:

- Linear components u_{sd}^{lin} , u_{sq}^{lin}
- Decoupling components $u_{sd}^{decouple}$, $u_{sq}^{decouple}$.

The equations are decoupled as follows:

$$u_{sd} = u_{sd}^{lin} + u_{sd}^{decouple} = \left[K_R i_{sd} + K_L \frac{d}{dt} i_{sd} \right] - \left[\omega_s K_L i_{sq} + \frac{\Psi_{rd} L_m}{L_r T_r} \right] \quad \text{EQ. 4-11}$$

$$u_{sq} = u_{sq}^{lin} + u_{sq}^{decouple} = \left[K_R i_{sq} + K_L \frac{d}{dt} i_{sq} \right] + \left[\omega_s K_L i_{sd} + \frac{L_m}{L_r} \omega \Psi_{rd} \right] \quad \text{EQ. 4-12}$$

Where:

$$K_R = R_s + \frac{L_m^2}{L_r} R_r \quad \text{EQ. 4-13}$$

$$K_L = L_s - \frac{L_m^2}{L_r} \quad \text{EQ. 4-14}$$

The voltage components $u_{sd}^{lin}, u_{sq}^{lin}$ are the outputs of the current controllers which control i_{sd} and i_{sq} components. They are added to the decoupling voltage components $u_{sd}^{decouple}, u_{sq}^{decouple}$ to yield direct and quadrature components of the terminal output voltage. This means the voltage on the outputs of the current controllers is:

$$u_{sd}^{lin} = K_R i_{sd} + K_L \frac{d}{dt} i_{sd} \quad \text{EQ. 4-15}$$

$$u_{sq}^{lin} = K_R i_{sq} + K_L \frac{d}{dt} i_{sq} \quad \text{EQ. 4-16}$$

The decoupling components are:

$$u_{sd}^{decouple} = - \left(\omega_s K_L i_{sq} + \frac{L_m}{L_r T_r} \Psi_{rd} \right) \quad \text{EQ. 4-17}$$

$$u_{sq}^{decouple} = \left(\omega_s K_L i_{sd} + \frac{L_m}{L_r} \omega \Psi_{rd} \right) \quad \text{EQ. 4-18}$$

As shown, the decoupling algorithm transforms the nonlinear motor model to linear equations which can be controlled by general PI or PID controllers instead of complicated controllers.

4.6 Space Vector Modulation

Space Vector Modulation (SVM) can directly transform the stator voltage vectors from an α, β -coordinate system to Pulse Width Modulation (PWM) signals (duty cycle values).

The standard technique for output voltage generation uses an inverse Clarke transformation to obtain 3-phase values. Using the phase voltage values, the duty cycles needed to control the power stage switches are then calculated. Although this technique gives good results, space vector modulation is more straightforward (valid only for transformation from the α, β -coordinate system).

The basic principle of the standard space vector modulation technique can be explained with the help of the power stage schematic diagram depicted in **Figure 4-4**.

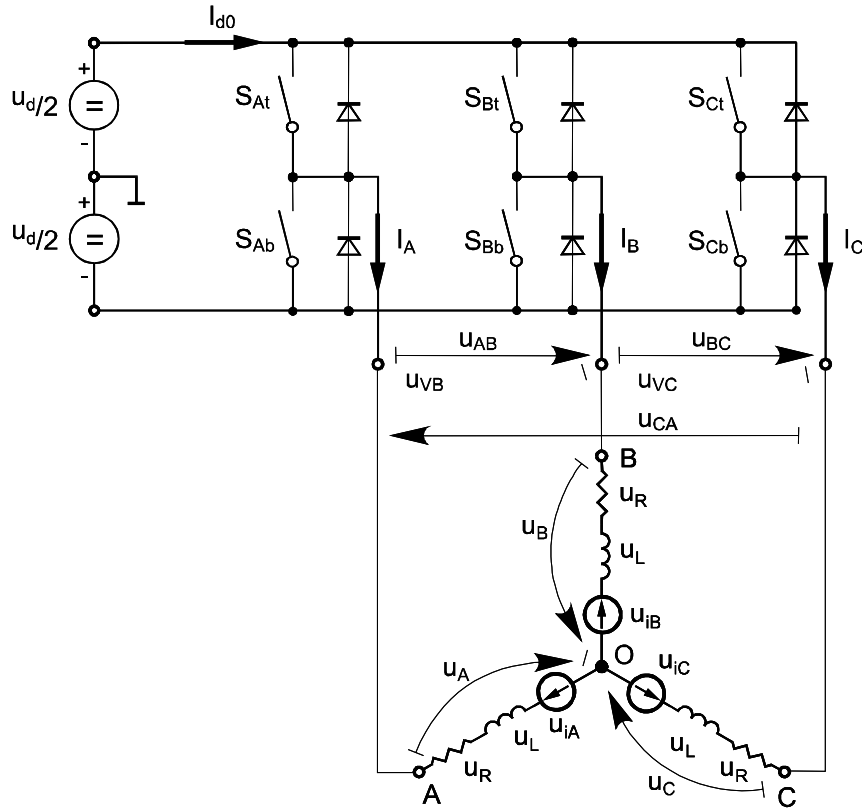

Figure 4-4. Power Stage Schematic Diagram

In the 3-phase power stage configuration, shown in **Figure 4-4**, eight possible switching states (vectors) are possible and given by combinations of the corresponding power switches. The graphical representation of all combinations is the hexagon shown in **Figure 4-5**. There are six non-zero vectors, $U_0, U_{60}, U_{120}, U_{180}, U_{240}, U_{300}$, and two zero vectors, O_{000} and O_{111} , defined in α, β coordinates.

The combination of ON / OFF states of the power stage switches for each voltage vector is coded in **Figure 4-5** by the three-digit number in parenthesis. Each digit represents one phase. For each phase, a value of one means that the upper switch is ON and the bottom switch is OFF. A value of zero means that the upper switch is OFF and the bottom switch is ON. These states, together with the resulting instantaneous output line-to-line voltages, phase voltages and voltage vectors, are listed in **Table 4-1**.

Table 4-1. Switching Patterns and Resulting Instantaneous Line-to-Line and Phase Voltages

a	b	c	U_a	U_b	U_c	U_{AB}	U_{BC}	U_{CA}	Vector
0	0	0	0	0	0	0	0	0	O_{000}
1	0	0	$2U_{DCBus}/3$	$-U_{DCBus}/3$	$-U_{DCBus}/3$	U_{DCBus}	0	$-U_{DCBus}$	U_0
1	1	0	$U_{DCBus}/3$	$U_{DCBus}/3$	$-2U_{DCBus}/3$	0	U_{DCBus}	$-U_{DCBus}$	U_{60}
0	1	0	$-U_{DCBus}/3$	$2U_{DCBus}/3$	$-U_{DCBus}/3$	$-U_{DCBus}$	U_{DCBus}	0	U_{120}
0	1	1	$-2U_{DCBus}/3$	$U_{DCBus}/3$	$U_{DCBus}/3$	$-U_{DCBus}$	0	U_{DCBus}	U_{240}
0	0	1	$-U_{DCBus}/3$	$-U_{DCBus}/3$	$2U_{DCBus}/3$	0	$-U_{DCBus}$	U_{DCBus}	U_{300}
1	0	1	$U_{DCBus}/3$	$-2U_{DCBus}/3$	$U_{DCBus}/3$	U_{DCBus}	$-U_{DCBus}$	0	U_{360}
1	1	1	0	0	0	0	0	0	O_{111}

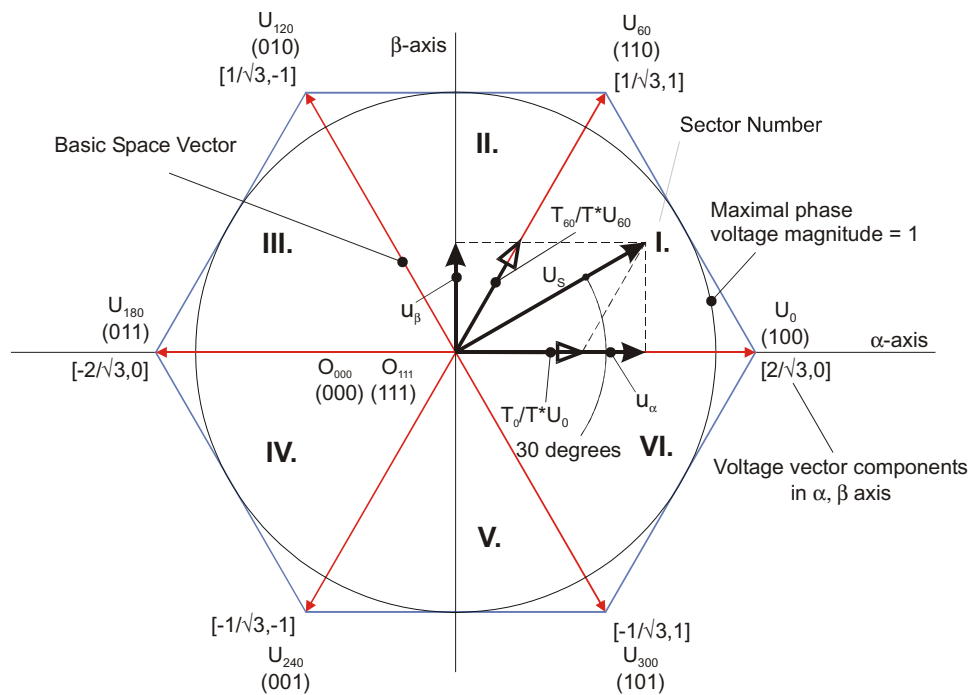

Figure 4-5. Basic Space Vectors and Voltage Vector Projection

SVM is a technique used as a direct bridge between vector control (voltage space vector) and PWM.

The SVM technique consists of several steps:

1. Sector identification
2. Space voltage vector decomposition into directions of sector base vectors U_x , $U_{x\pm 60}$
3. PWM duty cycle calculation

In SVM, the voltage vectors U_{XXX} and O_{XXX} for certain instances are applied in such a way that the “mean vector” of the PWM period T_{PWM} is equal to the desired voltage vector.

This method yields the greatest variability of arrangement of the zero and non-zero vectors during the PWM period. One can arrange these vectors to lower switching losses; another might want to approach a different result, such as center-aligned PWM, edge-aligned PWM, minimal switching, etc.

For the chosen SVM, the following rule is defined:

- The desired space voltage vector is created only by applying the sector base vectors:
 - The non-zero vectors on the sector side, ($U_x, U_{x\pm 60}$)
 - The zero vectors (O_{000} or O_{111})

The following expressions define the principle of the SVM:

$$T_{PWM} \cdot U_{S[\alpha, \beta]} = T_1 \cdot U_x + T_2 \cdot U_{x\pm 60} + T_0 \cdot (O_{000} \vee O_{111}) \quad \text{EQ. 4-19}$$

$$T_{PWM} = T_1 + T_2 + T_0 \quad \text{EQ. 4-20}$$

In order to solve the time periods T_0 , T_1 and T_2 , it is necessary to decompose the space voltage vector $U_{S[\alpha, \beta]}$ into directions of the sector base vectors $U_x, U_{x\pm 60}$. **EQ. 4-19** splits into equations **EQ. 4-21** and **EQ. 4-22**:

$$T_{PWM} \cdot U_{Sx} = T_1 \cdot U_x \quad \text{EQ. 4-21}$$

$$T_{PWM} \cdot U_{S(x\pm 60)} = T_2 \cdot U_{x\pm 60} \quad \text{EQ. 4-22}$$

By solving this set of equations, it's possible to calculate the necessary duration of the application of the sector base vectors $U_x, U_{x\pm 60}$ during the PWM period T_{PWM} to produce the right stator voltages.

$$T_1 = \frac{|U_{Sx}|}{|U_x|} T_{PWM} \quad \text{for vector } U_x \quad \text{EQ. 4-23}$$

$$T_2 = \frac{|U_{Sx}|}{|U_{x\pm 60}|} T_{PWM} \quad \text{for vector } U_{x\pm 60} \quad \text{EQ. 4-24}$$

$$T_0 = T_{PWM} - (T_1 + T_2) \quad \text{either for } O_{000} \text{ or } O_{111} \quad \text{EQ. 4-25}$$

5. Design Concept of ACIM Vector Control Drives

5.1 System Outline

The system is designed to drive a 3-phase AC Induction Motor (ACIM). The application has the following specifications:

- Vector control technique used for ACIM control
- Speed control loop of the ACIM
- Targeted for a 56F80xEVM / 56F83xxEVM plus a Legacy Motor Daughter Card (LMDC)
- Runs on 3-phase AC induction motor control development platform at a variable line voltage of 115 / 230V AC (range -15% to +10%)

- The control technique incorporates:
 - Speed control loop with an inner q axis stator current loop
 - Rotor flux control loop with an inner d axis stator current loop
 - Field-weakening technique
 - Stator phase current measurement method
 - AC induction flux model calculation in an α, β -stationary reference frame
 - Forward Clarke and inverse Park transformations
 - D-q establishment allows transformation from the stationary reference frame to the rotating reference frame
 - DCBus ripple elimination
 - Space Vector Modulation (SVM)
- Motor mode
- Generator mode
- DCBus brake
- Minimum speed of 50rpm
- Maximum speed of 2500rpm at input power line 230V AC
- Maximum speed 1100rpm at input power line 115V AC
- Manual interface:
 - RUN / STOP switch
 - UP / DOWN push buttons control
 - LED indication
- Fault protection against:
 - Overvoltage
 - Undervoltage
 - Overcurrent
 - Overheating
- PC remote control interface:
 - Run / Stop motor push buttons
 - Speed set up
- PC master software remote monitor:
 - PC master software monitor interface:
 - Required speed
 - Actual motor speed
 - PC master software mode
 - START MOTOR / STOP MOTOR controls
 - Drive fault status
 - DCBus voltage level
 - Identified power stage boards
 - Drive status
 - Mains detection
 - PC master software speed scope observes actual and desired speed

5.2 Application Description

The vector control algorithm is calculated on Freescale's 56F80x or 56F8300 devices. According to the user-required inputs and measured and calculated signals, the algorithm generates 3-phase PWM signals for an AC induction motor inverter.

The block diagram of the ACIM control algorithm is shown in [Figure 5-1](#), which describes the structure of the vector control algorithm (basic blocks and control signals) being implemented.

The system incorporates the following hardware components:

- 3-phase AC induction motor with load coupled on the motor shaft
- 3-phase AC / BLDC high-voltage power stage
- 56F80xEVM or 56F83xx EVM plus an LMDC
- In-line optoisolation box, Freescale Part #ECOPTINL, which is connected between the host computer and the 56F80xEVM or 56F83xxEVM

The drive can be controlled in two operating modes:

- In the **Manual operating mode**, the required speed is set by the UP / DOWN push buttons; the drive is started and stopped by the RUN / STOP switch on the EVM board
- In the **PC remote control operating mode**, the required speed is set by the PC master software bar graph; the drive is started and stopped by the START MOTOR and STOP MOTOR controls

Measured quantities:

- DCBus voltage
- Phase currents (Phase A, Phase B, Phase C)
- Power module temperature
- Rotor speed

The faults used for drive protection:

- Overvoltage
- Undervoltage
- Overcurrent
- Overheating
- Mains out of range
- Overload

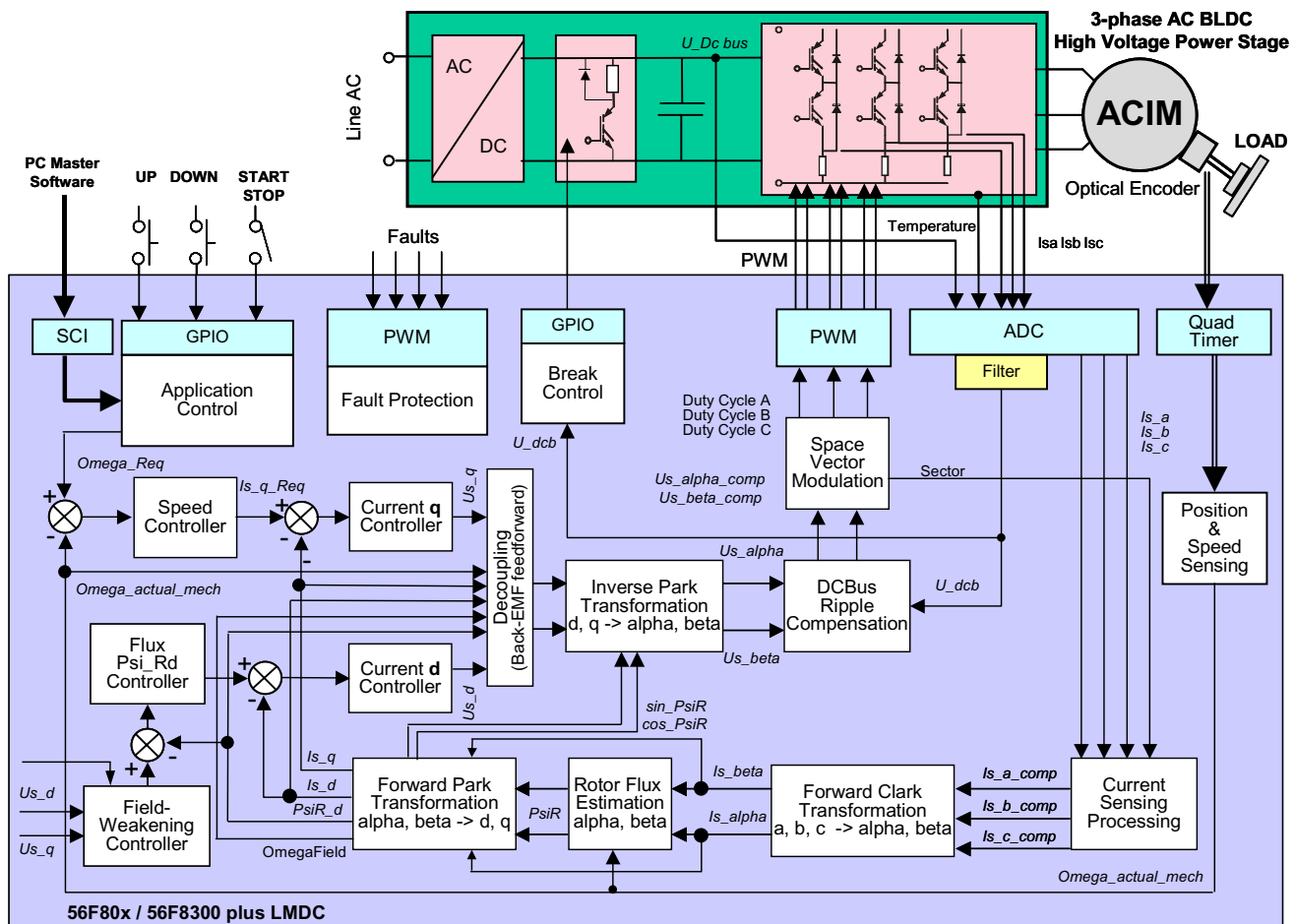

Figure 5-1. AC Induction Motor Vector Control Drive Structure

5.2.1 Control Process

After reset, the drive is in the INIT state and in the manual operation mode. When the RUN / STOP switch is detected in the stop position and there are no faults pending, the INIT state is changed to the STOP state. Otherwise, the drive waits in the INIT state. If a fault occurs, it goes to the FAULT state. In the INIT and STOP states, the operating mode can be changed from the PC master software. In the manual operating mode, the application is controlled by the RUN / STOP switch and UP / DOWN push buttons; in the PC remote-control mode, the application is controlled by the PC master software.

When the start command is accepted (from the RUN / STOP switch or the PC master software command), the STOP state is changed to the RUN state. The required speed is then calculated from the UP / DOWN push buttons or PC master software commands, if in PC remote control mode. The required speed is the input into the acceleration / deceleration ramp and the output is used as a reference command for the speed controller; see [Figure 5-1](#). The difference between the actual speed and the required speed generates a speed error. Based on the error, the speed controller generates an $I_{s_q_Req}$ current which corresponds to the torque component. The second component of the stator current is $I_{s_d_Req}$, which corresponds to the rotor flux, and is given by the flux controller. The field-weakening algorithm generates the required rotor flux, which is compared to the

calculated rotor flux from the *AC induction flux model calculation* algorithm. The difference between the required rotor flux and calculated rotor flux generates a flux error. Based on the flux error, the flux controller generates the required $I_{s_d_Req}$ stator current. Simultaneously, the stator currents I_{s_a} , I_{s_b} and I_{s_c} (a 3-phase system) are measured and transformed consecutively to the stationary reference frame α , β (a 2-phase system) and to the d-q rotating reference frame. The decoupling algorithm generates U_{s_q} and U_{s_d} voltages (d-q rotating reference frame). The U_{s_q} and U_{s_d} voltages are transformed back to the stationary reference frame α , β . The space vector modulation then generates the 3-phase voltage system, which is applied to the motor.

5.2.2 Drive Protection

The DCBus voltage, DCBus current and power stage temperature are measured during the control process. They are used for the overvoltage, undervoltage, overcurrent and overheating protection of the drive. The undervoltage and the overheating protection is performed by software. The overcurrent and the overvoltage fault signals utilize fault inputs of the hybrid controller controlled by hardware. Line voltage is measured during application initialization. According to the detected voltage level, the 115VAC or 230VAC mains is recognized. If the mains is out of the -15% to +10% range, the “Mains out of range” fault is set, and drive operation is disabled.

If any of the mentioned faults occur, the motor control PWM outputs are disabled in order to protect the drive and the application enters the FAULT state. The FAULT state can be left only when the fault conditions disappear and the RUN / STOP switch is moved to the STOP position (in the PC remote control mode by PC master software).

5.2.3 Indication of the Application States

If the application is running and motor spinning is disabled (i.e., the system is ready), the green user LED blinks at a 2Hz frequency (slower). When motor spinning is enabled, the green user LED is turned on and the actual state of the PWM outputs is indicated by PWM output LEDs. If any fault occurs (overcurrent, overvoltage, undervoltage, mains out of range or overheating), the green user LED blinks at an 8Hz frequency (faster). The PC master software control page shows the identified faults. The faults can be handled by switching the RUN / STOP switch to STOP in manual operating mode or by pushing the START MOTOR / STOP MOTOR buttons to the STOP MOTOR state in PC remote control mode to acknowledge the fault state. Meanwhile, the “Mains out of range” fault can be exited only with an application reset. It is strongly recommended that the user inspect the entire application to locate the source of the fault before restart.

6. Hardware Implementation

This section details the hardware implementation to target the 56F83xxEVM.

The application can run on Freescale’s motor control hybrid controllers using the 56F83xxEVM.

Setting up the hardware system for a particular hybrid controller varies only by the EVM used. Application software is identical for all devices.

The application can run on the following motor control platform:

- 3-phase AC induction motor

System configuration is shown in [Figure 6-1](#).

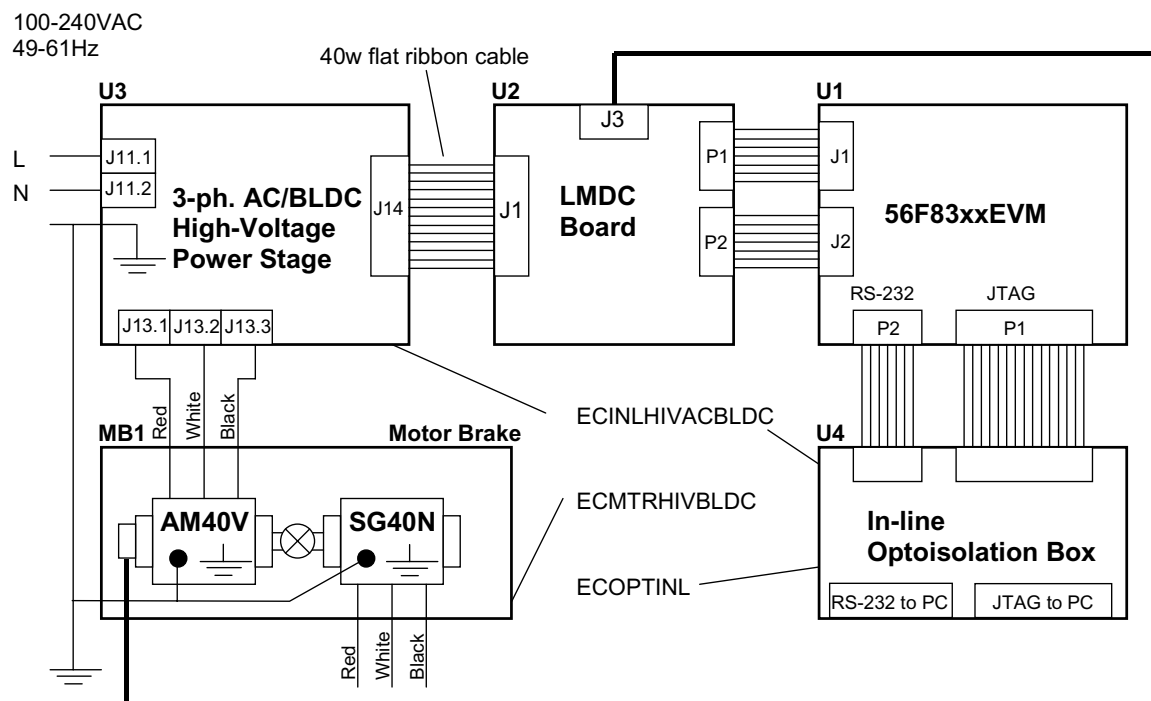

Figure 6-1. 3-Phase AC Induction Motor Configuration

All the system parts are supplied and documented according to the following references:

- U1 - Controller Board for 56F83xx
 - Supplied as 56F83xxEVM
 - Described in the appropriate **56F83xx Evaluation Module Hardware User's Manual** for the device being implemented
 - U2 - Legacy Motor Daughter Card (LMDC)
 - Supplies limited; please contact your Freescale representative
 - U3 - 3-phase AC / BLDC High-Voltage Power Stage
 - Supplied in a kit with In-Line Optoisolation Box as Freescale Part #ECINLHIVACBLDC
 - Described in **3-phase AC / BLDC High Voltage Power Stage User Manual**
 - U4 - In-Line Optoisolation Box
 - Supplied in a kit with 3-phase AC / BLDC High-Voltage Power Stage as: Freescale Part #ECINLHIVACBLDC
- Or
- Separately as Freescale Part #ECOPTINL
 - Described in: **MEMCILOBUM/D - In-Line Optoisolation Box**

Warning: The user **must** use the In-line Optoisolation Box during development to avoid damage to the development equipment.

- **MB1** Motor-Brake AM40V + SG40N

Detailed descriptions of individual boards can be found in comprehensive user manual for each board or on the Freescale web site: www.freescale.com.

Each manual includes the schematic of the board, description of individual function blocks and a bill of materials. An individual board can be ordered from Freescale as a standard product.

The AC induction motor-brake set incorporates a 3-phase AC induction motor and an attached BLDC motor brake. The AC induction motor has four poles. The incremental position encoder is coupled to the motor shaft, and position Hall sensors are mounted between motor and brake. They allow sensing of the position if required by the control algorithm. Detailed motor-brake specifications are listed in [Table 6-1](#).

Table 6-1. Motor - Brake Specifications

Set Manufactured	EM Brno, Czech Republic	
Motor	Motor Type	AM40V 3-Phase AC Induction Motor
	Pole Number	4
	Nominal Speed	1300rpm
	Nominal Voltage	3 x 200V
	Nominal Current	0.88A
Brake	Brake Type	SG40N 3-Phase BLDC Motor
	Nominal Voltage	3 x 27V
	Nominal Current	2.6A
	Pole Number	6
	Nominal Speed	1500rpm
Position Encoder	Type	Baumer Electric BHK 16.05A 1024-12-5
	Pulses per Revolution	1024

7. Software Implementation

This section describes the software implementation for targeting the 56F83xxEVM.

This section describes the software design of the AC induction vector control drive application by first discussing the devices' numerical scaling in fixed-point fractional arithmetic. Next, the control software is described in terms of:

- Software flowchart
- Control algorithm data flow
- State diagram

Finally, particular issues such as speed and current sensing are explained.

7.1 Analog Value Scaling

The AC induction motor vector control application uses a fractional representation for all real quantities, except time. The N-bit signed fractional format is represented using the 1.[N-1] format (1 sign bit, N-1 fractional bits). Signed fractional numbers (SF) lie in the following range:

$$-1.0 \leq SF \leq +1.0 \cdot 2^{-[N-1]} \quad \text{EQ. 7-1}$$

For words and long-word signed fractions, the most negative number that can be represented is -1.0, whose internal representation is \$8000 and \$80000000, respectively. The most positive word is \$7FFF or $1.0 - 2^{-15}$, and the most positive long-word is \$7FFFFFFF or $1.0 - 2^{-31}$.

The following equation shows the relationship between a real and a fractional representation:

$$\text{Fractional Value} = \frac{\text{Real Value}}{\text{Real Quantity Range}} \quad \text{EQ. 7-2}$$

7.1.1 Voltage Scaling

Voltage quantities are scaled to the maximum measurable voltage, which is dependent on the hardware. The relationship between real and fractional representations of voltage quantities is:

$$u_{Frac} = \frac{u_{Real}}{u_{Max}} \quad \text{EQ. 7-3}$$

where:

- u_{Frac} = Fractional representation of voltage quantities [-]
- u_{Real} = Real voltage quantities in physical units [V]
- u_{Max} = Maximum defined voltage used for scaling in physical units [V]

In the application, the u_{Max} value is the maximum measurable DCBus voltage:

$$u_{Max} = 407 \text{ V}$$

Other application voltage variables are scaled in the same way (u_{dc_bus} , $u_{dc_bus_filt}$, $u_{SAlphaBeta}$, u_{SDQ_ref} , u_{SDQ} , u_{Sabc} , $u_{Samplitude}$, etc.).

7.1.2 Current Scaling

The current quantities are scaled to the maximum measurable current, which is dependent on the hardware. The relationship between real and fractional representation of current quantities is:

$$i_{Frac} = \frac{i_{Real}}{i_{Max}} \quad \text{EQ. 7-4}$$

where:

i_{Frac}	=	Fractional representation of current quantities [-]
i_{Real}	=	Real current quantities in physical units [A]
i_{Max}	=	Maximum defined current used for scaling in physical units [A]

In the application, the i_{Max} value is the maximum measurable current:

$$i_{Max} = 5.86 \text{ A}$$

Other application current variables are scaled in the same way (i_Sabc_comp , $i_SAlphaBeta$, i_Sphase_max , $i_SD_desired$, $i_SQ_desired$, etc.).

7.1.3 Flux Scaling

Magnetic flux quantities are scaled to the maximum motor flux, which is dependent on the motor used. The maximum flux can be expressed as:

$$\Psi_{Max} \approx C_{sf} \cdot \frac{60 \cdot \sqrt{2}}{2 \cdot \pi \cdot \sqrt{3}} \cdot \frac{u_{nom}}{p_p \cdot n_s} \quad \text{EQ. 7-5}$$

where:

Ψ_{Max}	=	Maximum calculated flux value used for scaling in physical units [Vs]
u_{nom}	=	Nominal line-to-line voltage of motors [V]
n_s	=	Motor-synchronous speed dependent on pair of poles [rpm]
p_p	=	Number of pole pairs [-]
C_{sf}	=	Safety margin constant [-]

The relationship between real and fractional representation of flux quantities is:

$$\Psi_{Frac} = \frac{\Psi_{Real}}{\Psi_{Max}} \quad \text{EQ. 7-6}$$

where:

Ψ_{Frac}	=	Fractional representation of flux quantities [-]
Ψ_{Real}	=	Real flux quantities in physical units [Vs]

In the application, the parameters for Ψ_{Max} calculation are:

$$u_{nom} = 200V$$

$$n_s = 1500rpm$$

$$p_p = 2$$

$$C_{sf} = 1.92$$

The maximum motor flux value is then:

$$\Psi_{Max} = 1 \text{ Vs}$$

Other application flux variables are scaled in the same way (*psi_RAlphaBeta*, *psi_RD_desired*, etc.).

7.1.4 Speed Scaling

Speed quantities are scaled to the defined maximum mechanical speed, which is dependent on the drive. The relationship between real and fractional representation of speed quantities is:

$$\omega_{Frac} = \frac{\omega_{Real}}{\omega_{Max}} \quad \text{EQ. 7-7}$$

Where:

ω_{Frac} = Fractional representation of speed quantities [-]

ω_{Real} = Real speed quantities in physical units [rpm]

ω_{Max} = Maximum defined speed used for scaling in physical units [rpm]

In the application, the ω_{Max} value is defined as:

$$\omega_{Max} = 4000rpm$$

Other speed variables are scaled in the same way (*omega_reqPCM_mech*, *omega_desired_mech*, *omega_required_mech*, *omega_reqMAX_mech*, *omega_reqMIN_mech*, *omega_actual_mech*).

7.2 Software Flowchart

The general software flowchart incorporates the main routine entered from reset and interrupt states. The overview of the software flowchart is shown in [Figure 7-1](#).

After reset, the main routine provides initialization of the drive parameters, the application and the hybrid controller; it then enters an endless background loop. The background loop contains the routines:

- Fault detection
- RUN / STOP Switch
- Required speed scan
- Brake control
- Application state machine

The following interrupt service routines (ISRs) are utilized:

- **PWMB Fault ISR** services faults invoked by an external hardware fault
- **ADC End of Scan ISR** services the ADC and provides the execution of the fast control loop; the ADC is synchronized with the PWM pulses. The PWM value registers are updated here. It is invoked with a 125 μ s period.
- **Timer C, Channel 0 On Compare ISR** provides the execution of the slow control loop, LED indication processing, push button processing and switch filtering; it is invoked with a 1000 μ s period.
- **SCI ISR** services PC master software communication

7.2.1 Initialization

Initialization occurs after reset. The first phase of initialization is PE's Low-Level Initialization, which initializes PE and the CPU. The next phase is done in the application code, which initializes drive parameters and peripherals. The drive parameters are set, then the application and hybrid controller initializations are executed.

The following drive parameters are set in the *DriveParamSet* routine:

- The output voltage structure is initialized to zero volts
- Parameters of the AC induction flux model are set
 - Integration state variables are reset
 - Motor-dependent constants are set
- Parameters of the d-q establishment algorithm are set
 - Rotor flux zero limit value is initialized
 - Motor-dependent constants are set
- Parameters of the decoupling algorithm are set
 - Motor-dependent constants are set
- Parameters of the torque- and flux-producing current components controllers and speed, flux and field-weakening controllers are set
 - Proportional and integral gain and their scaling constants are set
 - Controller output limits are set
 - Controller integral portion is reset to zero
- Currents limitation algorithm parameter is set
 - Maximum motor-current value is set
- States of the application state machine are set as follows:
 - Application state is set to INIT
 - Substate of application RUN state is set to DE-EXCITATION
 - Substate of application INIT state is set to BRANCH
- Application operating mode is set to MANUAL
- *PrimaryCtrl* bit in *appInitControl* control word is set
- RUN / STOP switch, switch filter and overload filter are initialized

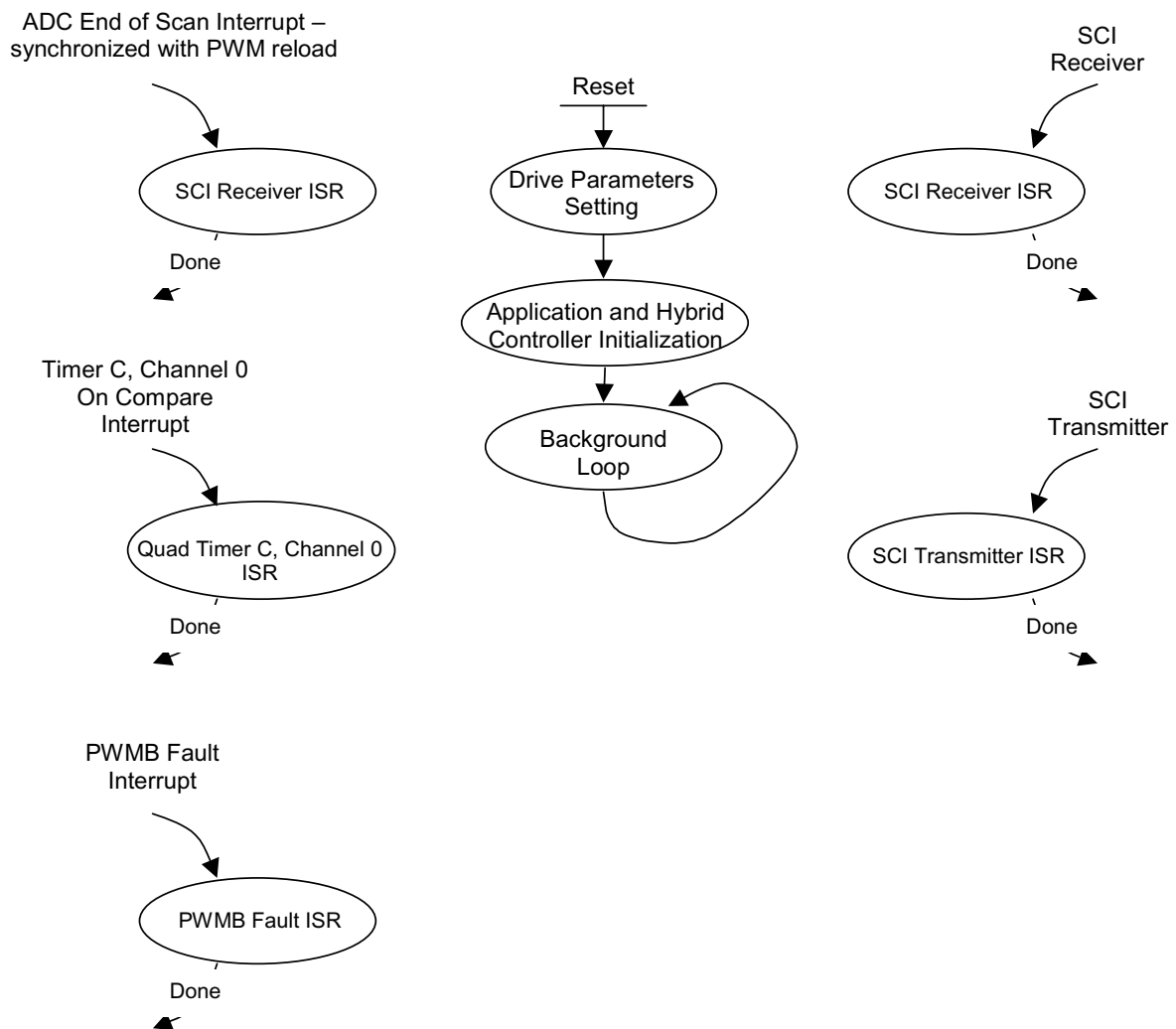

Figure 7-1. Software Flowchart Overview

After initialization of the drive parameters is completed, the application and hybrid controller initialization routine is executed:

- ADC channels are assigned to the sensed quantities
 - ADC Channel 2 to Sample 0 - Phase current A
 - ADC Channel 3 to Sample 1 - Phase current B
 - ADC Channel 4 to Sample 2 - Phase current C
 - ADC Channel 0 to Sample 4 - DCBus voltage
 - ADC Channel 5 to Sample 4, 5, 7 - power module temperature

- Quad Timer C, Channel 0 driver initialization (slow control loop time base)
 - Count Up
 - Prescaler 2
 - Interrupt On Compare (compare value set to 1000 μ s period)
 - Associate interrupt service routine with On Compare event
- Quad Timer C, Channel 3 driver initialization (ADC and PWM synchronization)
 - Count Up
 - Prescaler 1
 - Started by PWM reload signal
- Switch control is initialized
- PWMB fault interrupt service routine is initialized
- Brake control is initialized
- Speed and position measurement is initialized
 - Quad Timer B, Channels 0, 1, 2, 3 initialized for speed and position measurement. The position measurement (Quad Timer B, Channel 1) is not applied in the application.
 - Speed measurement-specific variables are initialized
- PWMA for status LEDs control is initialized
- Quad Timer C, Channel 0 is enabled
- Interrupts are enabled

7.2.2 Background Loop

After initialization, the background loop is entered. It runs in an endless loop and is asynchronously interrupted by the system interrupt service routines. The processes executed in the background are:

- Fault Detection
 - Fault DCBus overvoltage and overcurrent pins are scanned for a fault signal occurrence
 - Measured DCBus voltage in *u_dc_bus_filt* is checked for undervoltage
 - Measured power module temperature in *temperature_filt* is checked for overheating
 - Mains detection fault flag is checked
 - Drive overload fault is detected
 - When a fault occurs, the appropriate bits in *appFaultStatus* and *appFaultPending* words are set. The *FaultCtrl* bit in *appControl* is set to change the application state to FAULT.
- RUN / STOP Switch and Required Speed Scan
 - Based on the application operating mode, the process selects whether the Required Speed and RUN / STOP command are set manually with the switches and buttons or by the PC master software interface. The required speed is limited to maximum and minimum values.
- Brake Control Background
 - Sets the generator mode flag if the drive is running in the generator mode. If the drive is in motor mode, the brake switch is turned off.
- Application State Machine
 - Ensures the execution of the active application state and the transition between the states, according to bits in the application control word.

7.2.3 ADC End of Scan ISR

The ADC End of Scan ISR is the most critical and the routine most demanding of the processor's time. Most of the AC induction motor vector control processes must be linked to this ISR.

The Analog-to-Digital Converter is initiated synchronously with a PWM reload pulse. It simultaneously scans phase currents, phase voltage and temperature. When the conversion is finalized, the ADC End of Scan ISR is called. The PWM reload pulse frequency is set to every second PWM opportunity. For the PWM frequency of 16kHz, this means the PWM reload pulse frequency is 8kHz, which corresponds to the 125 μ s ADC End of Scan ISR period.

The routine calls control functions according to application state. If the application state is RUN, the *FastControlLoopEnabled* function is called; otherwise, the *FastControlLoopDisabled* function is called. The ADC End of Scan diagram is shown in [Figure 7-2](#).

The *FastControlLoopEnabled* function provides the following services and calculations:

- Sets a compare value for QuadTimer C, Channel 3, defining the ADC start, needed for phase current measurement
- Calls the analog-sensing and correction function
- Calls the forward Clarke transformation
- Calls the rotor flux model calculation
- Calls the d-q system establishment function
- Calls i_{sd} and i_{sq} current-component controllers
- Calls the decoupling algorithm
- Calls the inverse Park transformation
- Calls the DCBus ripple elimination function
- Calls the space vector modulation function
- Calls the analog-sensing correction reconfiguration function
- Passes calculated duty cycle ratios to the PWM driver
- Calls the brake control function

The *FastControlLoopDisabled* function is called in the application states when the vector control algorithm is not executed. The function services only the analog-sensing correction process, space vector modulation algorithm and PWM generation. The drive control variables are set to their initial values.

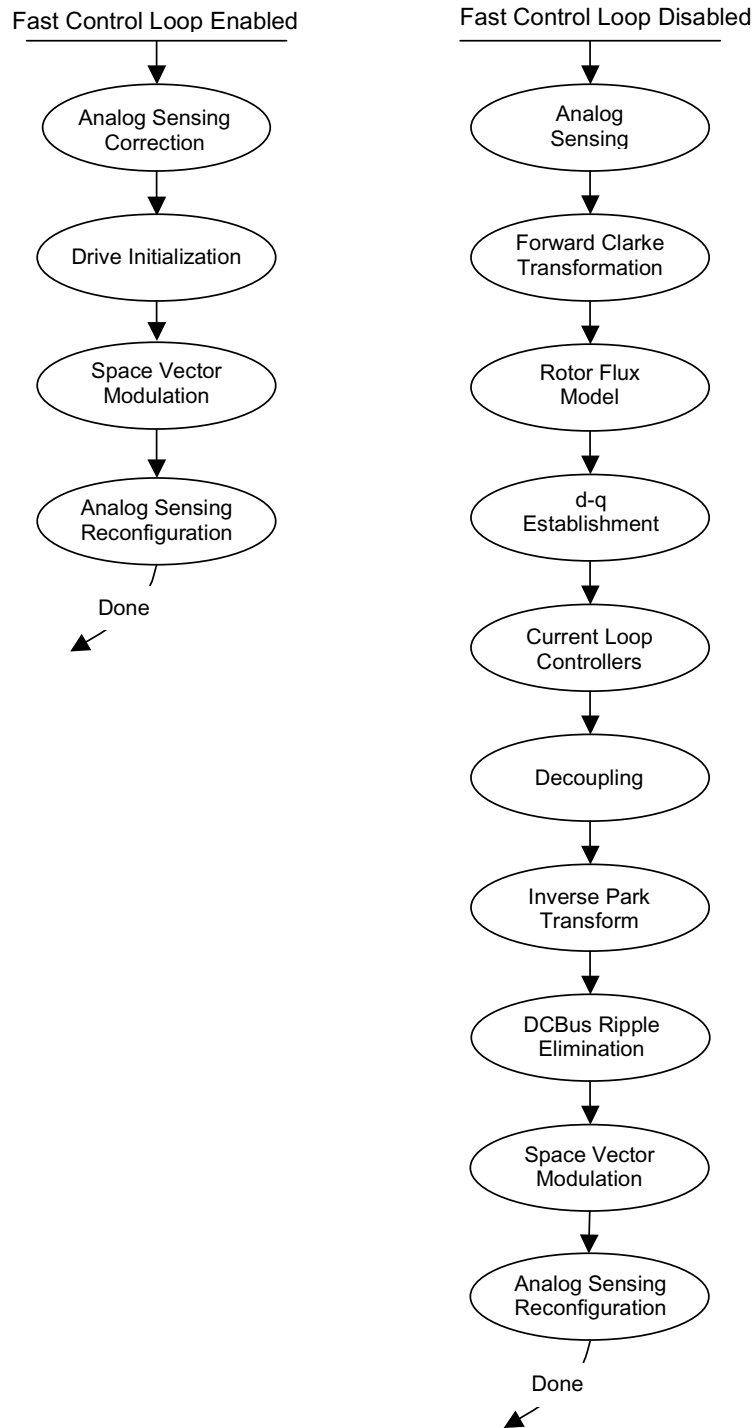

Figure 7-2. ADC End of Scan ISR

7.2.4 Quad Timer C, Channel 0, On Compare ISR

The routine calculates part of the vector control algorithm and handles LED indication, button processing and switch filtering. It is called with a 1000 μ s period. The tasks provided by individual functions are:

- Slow control loop is executed. It provides the part of vector control algorithm calculations, which can be executed in a slower control loop. The function *SlowControlLoopEnabled* is called.
 - Reads the actual motor speed and handles the speed measurement process
 - Executes the speed acceleration / deceleration ramp algorithm
 - Calculates the output stator voltage amplitude
 - Field-weakening controller is called
 - Rotor flux and speed controllers are called
 - Current limit algorithm is called
- LED indication process handles the LED indication of the application state. The LED indication process uses the PWMA module's LED outputs. (INIT, RUN, STOP, FAULT)
- Button processing handles the UP / DOWN button debounce counter
- Switch-filter processing handles the RUN / STOP switch filtering
- PC master software recorder routine is called

7.2.5 PWMB Fault ISR

The PWMB Fault ISR is the highest priority interrupt implemented in the software. In the case of DCBus, overcurrent or overvoltage fault detection, the external hardware circuit generates a fault signal that is detected on the fault input pin of the hybrid controller's PWMB module. The signal disables PWM outputs in order to protect the power stage and generates a fault interrupt where the fault condition is handled. The routine sets the records of the corresponding fault source to the fault status word and sets the fault bit in the application control word.

7.2.6 SCI ISR

The interrupt handler provides SCI communication and PC master software service routines. These routines are fully independent of the motor control tasks.

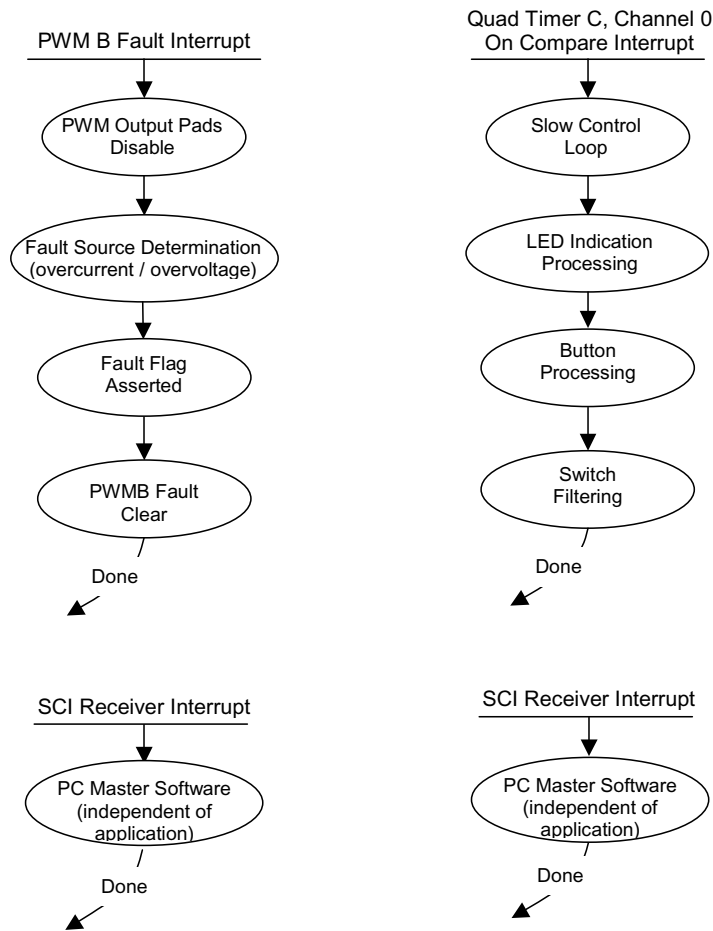

Figure 7-3. Application Interrupt Service Routines

7.3 Control Algorithm Data Flow

The 3-phase AC induction motor vector control algorithm data flow is described in [Figure 7-4](#), [Figure 7-5](#) and [Figure 7-6](#).

The individual processes are described in detail in the following sections.

7.3.1 Analog-Sensing Corrections

The analog-sensing process handles sensing, filtering and correction of analog variables (phase currents, temperature, DCBus voltage).

7.3.2 Speed Measurement

The speed measurement process provides the mechanical angular speed, *omega_actual_mech*.

7.3.3 Forward Clarke Transformation

The forward Clarke transformation transforms the 3-phase system (a, b, c) to a 2-phase orthogonal reference frame (α , β). For theoretical background, see [Section 4.2](#). The algorithm is included in the PE motor control function library. For more details, refer to the PE documentation.

7.3.4 Rotor Flux Model

The rotor flux model process calculates the rotor magnetic flux of the AC induction motor in the (α , β) 2-phase stationary reference frame. The flux model utilizes monitored rotor speed and stator voltages and currents. For theoretical background, see [Section 4.4](#). The algorithm is included in the PE motor control function library. For more details, refer to the PE documentation.

7.3.5 d-q System Establishment

This process transforms quantities from an (α , β) 2-phase reference frame attached to the stator into a d-q- 2-phase reference frame rotating with the magnetic flux angular speed. The rotor magnetic flux space vector is put into the d axis of the coordinate system. The function calculates the magnitude of the rotor magnetic flux and the sine and cosine of its position angle $theta_field$ in the (α , β) coordinate system. For theoretical background, see [Section 4.3](#). The algorithm is included in the PE motor control function library. For more details, refer to the PE documentation.

7.3.6 Decoupling

The decoupling process calculates the decoupling rotational voltage components of the AC induction machine in the d-q coordinate system and adds them to the outputs of the currents controllers which control the i_{sd} and i_{sq} components. It yields to the d and q output stator voltage components. The output voltage vector is limited to the desired limits. For theoretical background, see [Section 4.5](#). The algorithm is included in the PE motor control function library. For details, refer to the PE documentation.

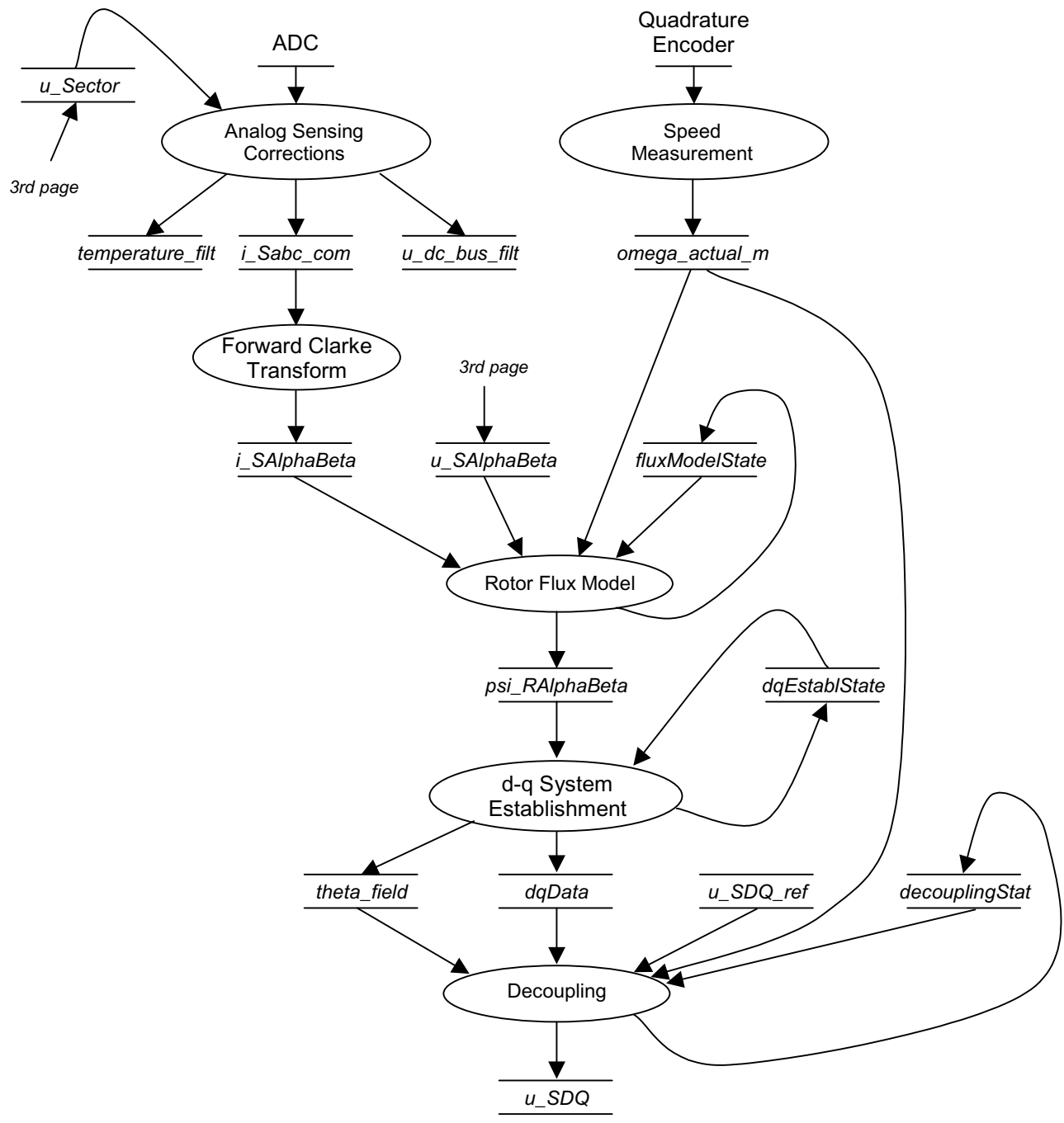

Figure 7-4. Vector Control Application Data Flow

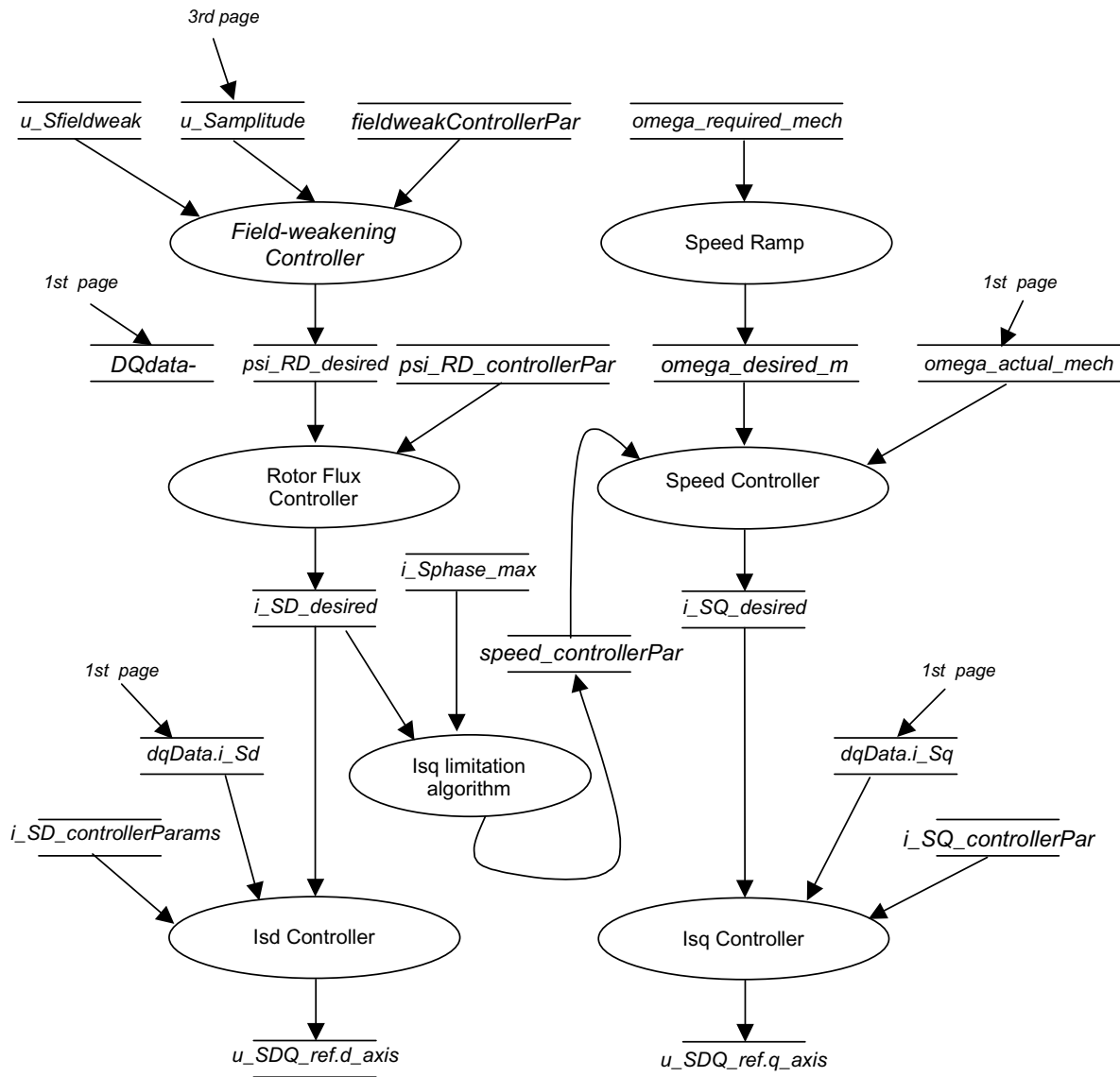

Figure 7-5. Controllers Data Flow

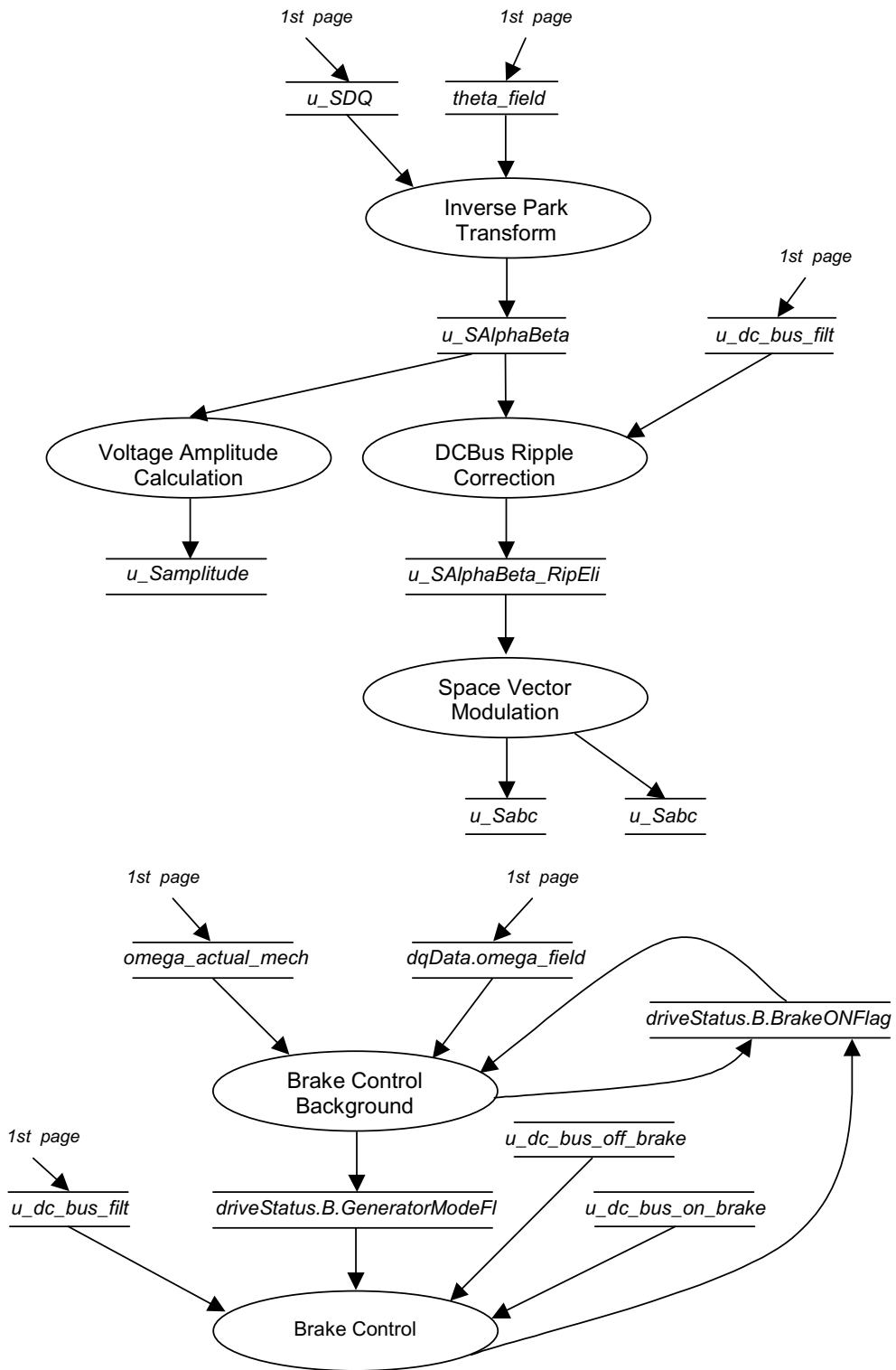

Figure 7-6. Space Vector Modulation and Brake Control Data Flow

7.3.7 Speed Ramp

This process calculates the desired speed ($\omega_{desired_mech}$), based on the required speed according to the acceleration / deceleration ramp. The required speed ($\omega_{required_mech}$) is determined either by the push buttons, if in manual mode, or by PC master software, if in PC remote control mode.

7.3.8 Speed Controller

This process calculates the desired i_{sq} stator current component ($i_{SQ_desired}$) according to the speed error, which is the difference between the actual and desired speeds. The PI controller is implemented.

7.3.9 I_{sq} Controller

This process calculates the linear portion of the stator voltage space vector q component ($u_{SDQ_ref.q_axis}$) based on the i_{sq} stator current component error, which is the difference between the actual and desired i_{sq} stator current components. The PI controller is implemented.

7.3.10 Field-Weakening Controller

The field-weakening process provides control of the desired rotor flux ($\psi_{RD_desired}$) in order to achieve a higher motor speed than nominal. It compares the actual output motor stator-voltage amplitude with nominal field-weakening voltage; the desired rotor flux is set based on the calculated error.

7.3.11 Flux Controller

This process calculates the desired i_{sd} stator current component ($i_{SD_desired}$) according to rotor flux error, which is the difference between the actual and desired rotor flux. The PI controller is implemented.

7.3.12 I_{sd} Controller

This process calculates the linear portion of the stator voltage space vector d component ($u_{SDQ_ref.d_axis}$), based on the i_{sd} stator current component error, which is the difference between the actual and desired i_{sd} stator current components.

7.3.13 Inverse Park Transformation

The Inverse Park Transformation process converts stator voltage space vector components from the rotating orthogonal coordinate system (d-q) attached to the rotor magnetic flux to the stationary orthogonal coordinate system (α,β) attached to the stator. For theoretical background, see [Section 4.3](#). The algorithm is included in the PE motor control function library. For more details, refer to the PE documentation.

7.3.14 DCBus Ripple Elimination

This process provides for the elimination of the voltage ripple on the DCBus. It compensates an amplitude of the direct- α and the quadrature- β components of the stator reference voltage vector U_S for imperfections in the DCBus voltage. The algorithm is included in the PE motor control function library. For more details, refer to the PE documentation.

7.3.15 Space Vector Modulation

This process directly transforms the stator voltage space vector from the α,β coordinate system to pulse width modulation (PWM) signals (duty cycle values). The duty cycle ratios are then passed to the PWM module in the *u_Sabc* structure. For theoretical background, see [Section 4.6](#). The algorithm is included in the PE motor control function library. For details, refer to the PE documentation.

7.3.16 Voltage Amplitude Calculation

This process provides a calculation of the actual stator voltage space vector magnitude from the d-q components of the stator voltage. The actual stator voltage amplitude is used in field-weakening. It is the value controlled by the field-weakening controller.

7.3.17 Brake Control Background

This process is executed in the background. It sets the generator mode flag if the drive is running in generator mode. If the drive is in motor mode, the generator mode flag is cleared. In motor mode, if the brake-on flag is set, the brake switch is turned off and the brake-on flag is cleared.

7.3.18 Brake Control

This process is executed in the ADC End of Scan ISR. If the generator mode flag is set, switching of the brake switch is enabled. The brake switch is turned on if the DCBus voltage is higher than *u_dc_bus_on_brake* and turned off if it is lower than *u_dc_bus_off_brake*. The brake-on flag is set if the switch is on and cleared if it is off.

Notes: Constants of controllers were designed using standard control theory in a continuous time domain. The step responses of the controlled system measured by the PC master software were used to investigate system parameters. The least-square method, programmed in Matlab, identified the respective system parameters in the Laplace domain. The parameters were designed using standard Matlab functions, such as the Bode plot of frequency response, Nyquist plot, step response, etc. The results in the continuous time domain were then transformed to the discrete time domain for use by the hybrid controller. In the application, the controller parameters were tuned slightly.

7.4 Application State Diagram

The processes previously described are implemented in the state machine, as illustrated in [Figure 7-7](#). The state machine provides transitions between the states INIT, STOP, RUN, FAULT.

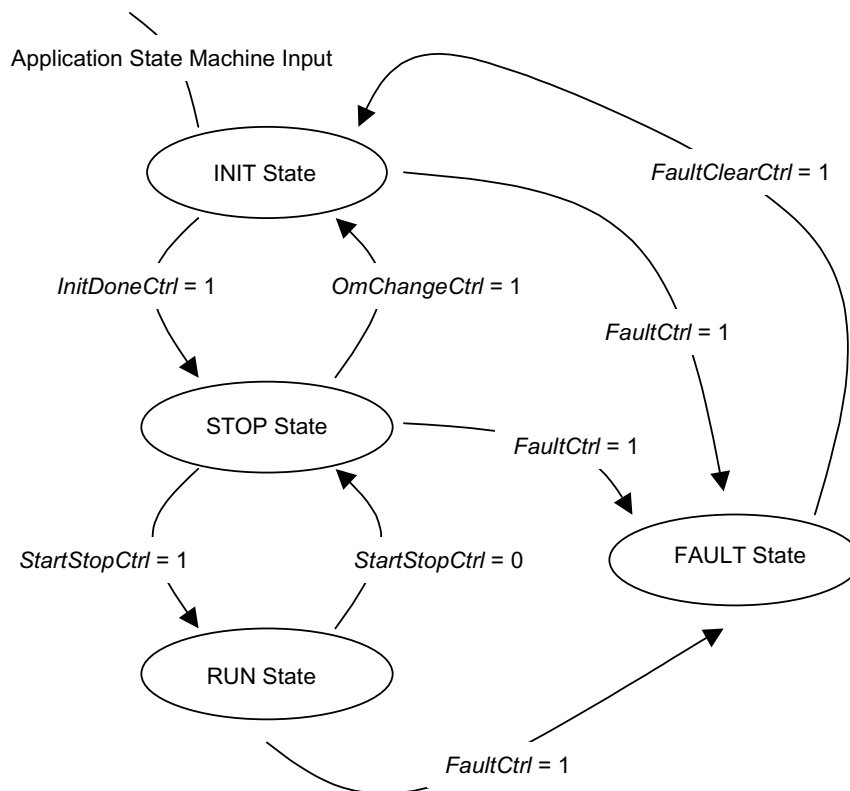

Figure 7-7. Application State Diagram

7.4.1 Application State - INIT

After reset, the application enters the INIT state, which provides hybrid controller and application initialization. In this state, the drive is disabled and the motor cannot be started. The INIT state is divided into three substates which handle the different phases of the INIT state. The substates of the INIT state are illustrated in [Figure 7-8](#). The tasks provided by the INIT substates are:

- The BRANCH substate decides whether or not the primary initialization is executed. It is entered any time there is a transition from any other state to the INIT state. It is entered just once, after the INIT state is set. It calls the transition function to either the PRIMARY or OPERATING MODE substates.
- The PRIMARY substate provides the primary initialization of the hybrid controller and the application. It is entered from the BRANCH substate after the application is reset or after a transition from a FAULT to an INIT application state. In the transition from the BRANCH to the PRIMARY substate, analog-sensing correction initialization is started. After the initialization is finished, mains detection is executed and the state is changed to the OPERATING MODE substate.
- The OPERATING MODE substate handles the operating mode change logic. It is entered from the BRANCH or PRIMARY substates and sets the actual operating mode (MANUAL or PC_MASTER). This state can be exited only if the RUN / STOP switch is in the stop position and the application transits to the STOP state. If the switch is in the start position, the application remains in the INIT state; it serves as protection against start after reset if the RUN / STOP switch is in the start position.

If any fault is detected, the application transits to the FAULT state (protection against fault).

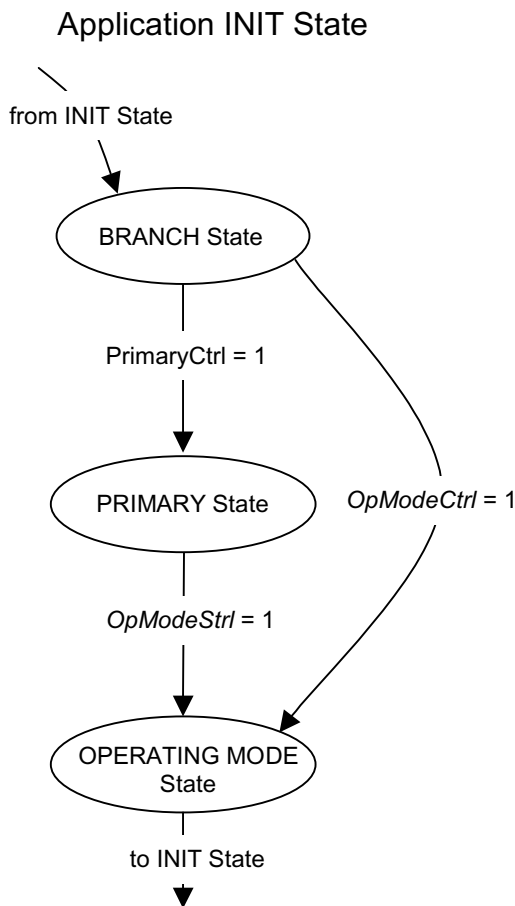

Figure 7-8. INIT State Substates State Machine

7.4.2 Application State - STOP

The STOP state can be entered either from the INIT state or the RUN state. The STOP state provides a motor standstill. In the STOP state, the drive is disabled, PWM output pads are disabled and the *FastControlLoopDisabled* function is called by the ADC End of Scan ISR. The application waits for the start command.

When the application is in the STOP state, the operating mode can be changed, either from manual mode to PC master software mode, or vice versa. When the operating mode request is asserted, the application always transits to the INIT state, where the mode is changed.

If a fault is detected in the STOP state, the application enters the FAULT state (fault protection). If no fault is present and the start command is accepted, the application transits to the RUN state and the motor is started.

7.4.3 Application State - RUN

The RUN state can be entered from the STOP state. The RUN state performs motor spinning. In the RUN state, the drive is enabled and the motor runs. The PWM output pads are enabled and the *FastControlLoopEnabled* function is called by the ADC End of Scan ISR. The RUN state is divided into three substates, which handle the different phases of the RUN state. The RUN substates' state machine is illustrated in [Figure 7-9](#). The tasks provided by the RUN substates are:

- The EXCITATION substate provides the excitation of the motor during start-up. It is entered after the transition from the STOP state; motor excitation is then enabled. After the motor is excited to the nominal rotor flux value, the substate is changed to SPINNING. If the stop command is accepted before the motor is fully excited, the substate is changed to DE-EXCITATION.
- The SPINNING substate provides motor spin and acceleration / deceleration. It is entered from the EXCITATION substate. The required speed command is accepted, and the motor spins at the required speed. If a stop command is accepted, the substate changes to DE-EXCITATION.
- The DE-EXCITATION substate provides de-excitation as the motor is going to the STOP state. It is entered from the EXCITATION or SPINNING substates. The speed command is set to zero turns. When zero turns are reached, motor de-excitation is executed. If the motor is de-excited, the application transits to the STOP state.

If any fault in the RUN state is detected, the application enters the FAULT state (fault protection).

7.4.4 Application State - FAULT

The FAULT state can be entered from any state. In the FAULT state, the drive is disabled and the application waits for the faults to be cleared.

When it detects that the fault has disappeared and the fault clear command is accepted, the RUN / STOP switch is moved to the stop position and the application transits to the INIT state. The “Wrong hardware” and “Mains out of range” faults can only be cleared by reset.

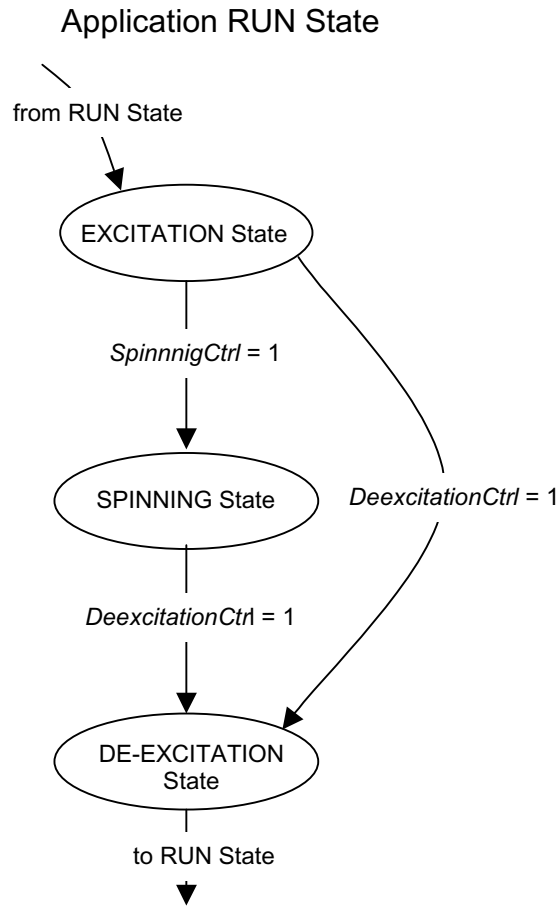

Figure 7-9. RUN State Substates State Machine

7.5 Speed Sensing

All members of Freescale’s 56F8300 family contain a Quadrature Decoder module, a commonly used peripheral for position and speed sensing. The Quadrature Decoder position counter counts up / down at each edge of the Phase A and Phase B signals according to their order; see [Figure 7-10](#).

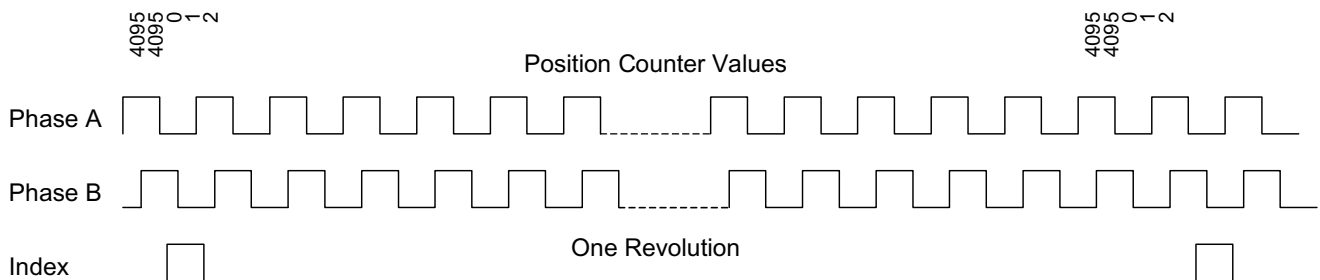

Figure 7-10. Quadrature Encoder Signals

In addition, the Quadrature Decoder input signals (Phase A, Phase B and Index) are connected to Quad Timer B. The Quad Timer contains four identical counter / timer groups. Due to the wide variability of Quad Timer modules, it is possible to use this module to decode Quadrature Encoder signals and to sense position and speed. The application presented uses the Quad Timer approach for speed measurement. The configuration of the Quad Timer is shown in [Figure 7-11](#). This configuration is ready for position sensing handled by Timer B1. In the AC induction motor vector control application presented, however, position sensing is not applied.

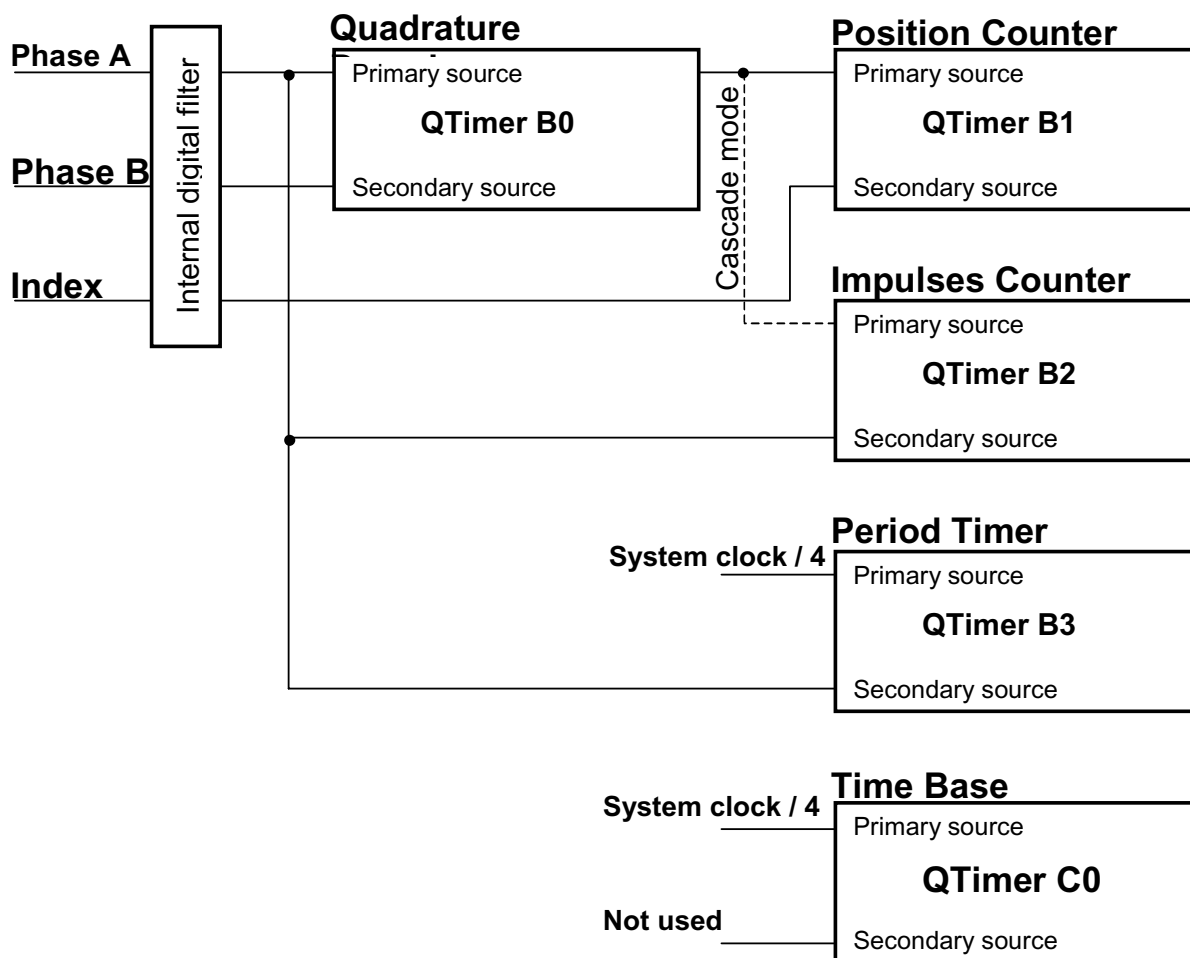

Figure 7-11. Quad Timer Module Configuration

7.5.1 Speed Sensing

There are two common ways to measure speed. The first method measures the time between two following edges of the quadrature encoder; the second method measures the position difference per constant period. The first method is used at low speed. At higher speeds, when the measured period is very short, the speed calculation algorithm switches to the second method.

The proposed algorithm combines both of the previously mentioned methods. The algorithm simultaneously measures the number of quadrature encoder pulses per constant period and their accurate time period. The speed can then be expressed as:

$$speed = \frac{k_1 \cdot N}{T} = \frac{k_1 \cdot N}{T_{clkT3} N_{clkT3}} = \frac{k \cdot N}{N_{clkT3}} \quad \text{EQ. 7-8}$$

Where:

$speed$	=	Calculated speed [-]
k	=	Scaling constant [-]
k_1	=	Scaling constant [s]
N	=	Number of counted pulses per constant period [-]
T	=	Accurate period of N pulses [s]
T_{clkT3}	=	Period of input clock to Timer B3 [s]
N_{clkT3}	=	Number of pulses counted by timer B3 [-]

The speed-sensing algorithm uses three timers (B0, B2, B3) in Quad Timer B and another timer as a time base (C0). The timer B0 is used in *quadrature count mode*, where the primary and secondary external inputs are decoded as Quadrature-Encoded signals. Timer B0 counts to zero and then reinitializes. Timers B2 and B3 are required for counting the quadrature signals and their period; see [Figure 7-11](#). Timer B2 counts the Quadrature Encoder pulses from Timer B0 and Timer B3 counts a system clock divided by 4. The values in both timers can be captured by each edge of the Phase A signal. The time base is provided by Timer C0, which is set to call a slow control loop every 1ms where the speed measurement is calculated. The speed processing algorithm works as follows:

1. The new captured values of both timers are read. The difference in the number of pulses and their accurate period are calculated from actual and previous values.
2. The new values are saved for the next period and the capture register is enabled. From this time, the first edge of the Phase A signal captures the values of both Timers B2, B3 and the capture register is disabled.
3. The speed is calculated using [EQ. 7-1](#)
4. This process is repeated with each call of the speed processing algorithm; see [Figure 7-12](#)

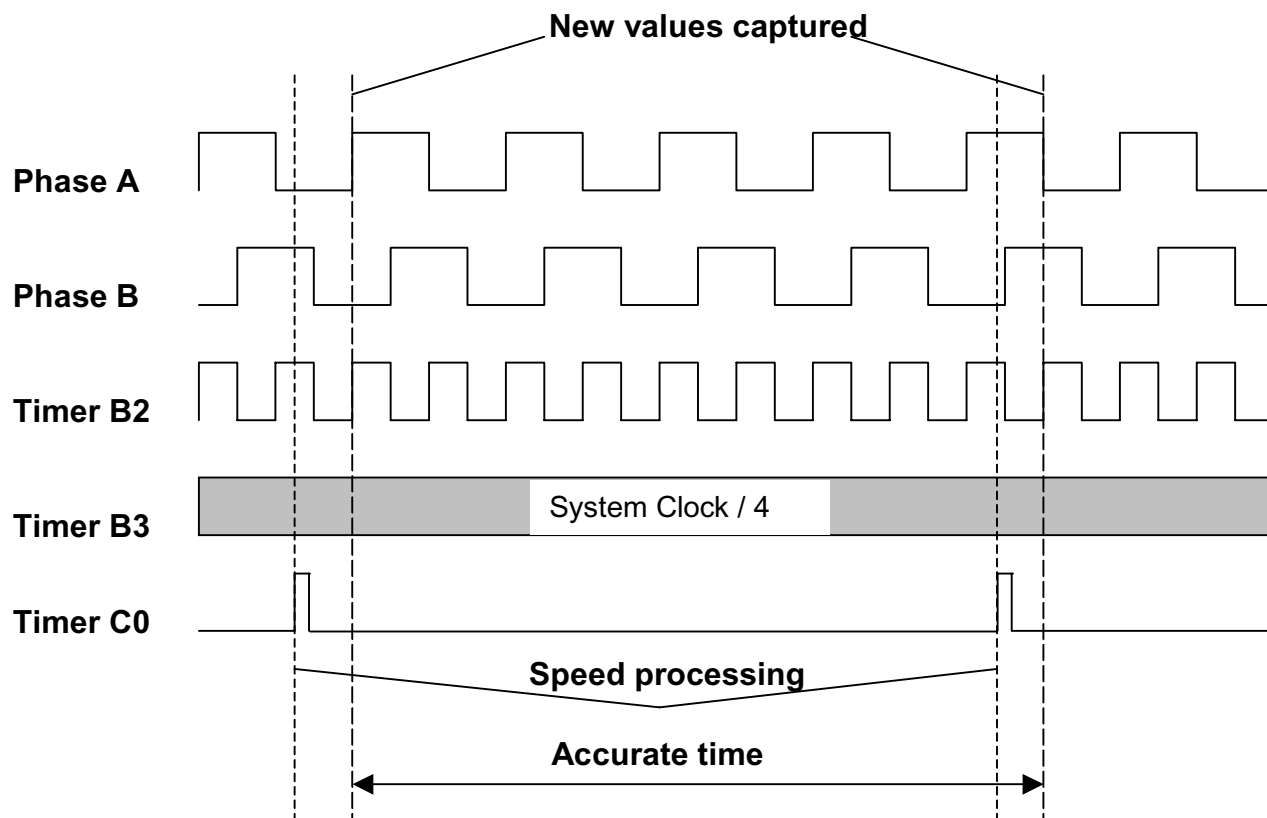

Figure 7-12. Speed Processing

7.5.1.1 Minimum and Maximum Speed Calculation

The minimum speed is calculated by the following equation:

$$v_{min} = \frac{60}{4N_E T_{calc}} \quad \text{EQ. 7-9}$$

Where:

- v_{min} = Minimum obtainable speed [rpm]
- N_E = Number of encoder pulses per revolution [-]
- T_{calc} = Period of speed measurement (calculation period) [s]

In this application, the Quadrature Encoder has 1024 pulses per revolution; the calculation period chosen is 1ms, based on the motor mechanical constant. Thus, [EQ. 7-1](#) calculates the minimum speed as 14.6 rpm.

The maximum speed can be expressed as:

$$v_{max} = \frac{60}{4N_E T_{clkT3}} \quad \text{EQ. 7-10}$$

Where:

v_{max}	=	Maximum obtainable speed [rpm]
N_E	=	Number of encoder pulses per revolution [-]
T_{clkT3}	=	Period of input clock to Timer B3 [s]

After substitution in **EQ. 7-10** for N and T_{clkT3} (Timer B3 input clock = system clock 30MHz/4), the maximum speed is calculated as 219,726rpm. As shown, the algorithm presented can measure speed within a wide speed range. Because such a high speed is not practical, the maximum speed can be reduced to the required range by a constant k in **EQ. 7-8**. The constant k can be calculated as:

$$k = \frac{60}{4N_E T_{clkT3} v_{max}} \quad \text{EQ. 7-11}$$

Where:

k	=	Scaling constant in the equation [-]
v_{max}	=	Maximum required speed [rpm]
N_E	=	Number of encoder pulses per revolution [-]
T_{clkT3}	=	Period of input clock to Timer B3 [s]

In the application presented, the maximum measurable speed is limited to 4000rpm.

Notes: To ensure correct speed calculation, the input clock of Timer B3 must be chosen so that the calculation period of speed processing (in this case, 1ms) is represented in Timer B3 as a value lower than 0x7FFF ($1000 \cdot 10^{-6} / T_{clkT2} \leq 0x7FFF$).

7.6 Analog Sensing

7.6.1 Current Sensing

The 56F8300 family provides the ability to synchronize the ADC and PWM modules via a SYNC signal. This exceptional hardware feature, which has been patented by Freescale, is used for current sensing. The PWM outputs a synchronization pulse, which is connected as an input to the synchronization module TC3 (Quad Timer C, channel 3). A high-true pulse occurs for each reload of the PWM regardless of the state of the LDOK bit. The intended purpose of TC3 is to provide a user-selectable delay between the PWM SYNC signal and the updating of the ADC values. A conversion process can be initiated by the SYNC input, which is an output of TC3. The time diagram of the automatic synchronization between PWM and ADC is shown in **Figure 7-13**.

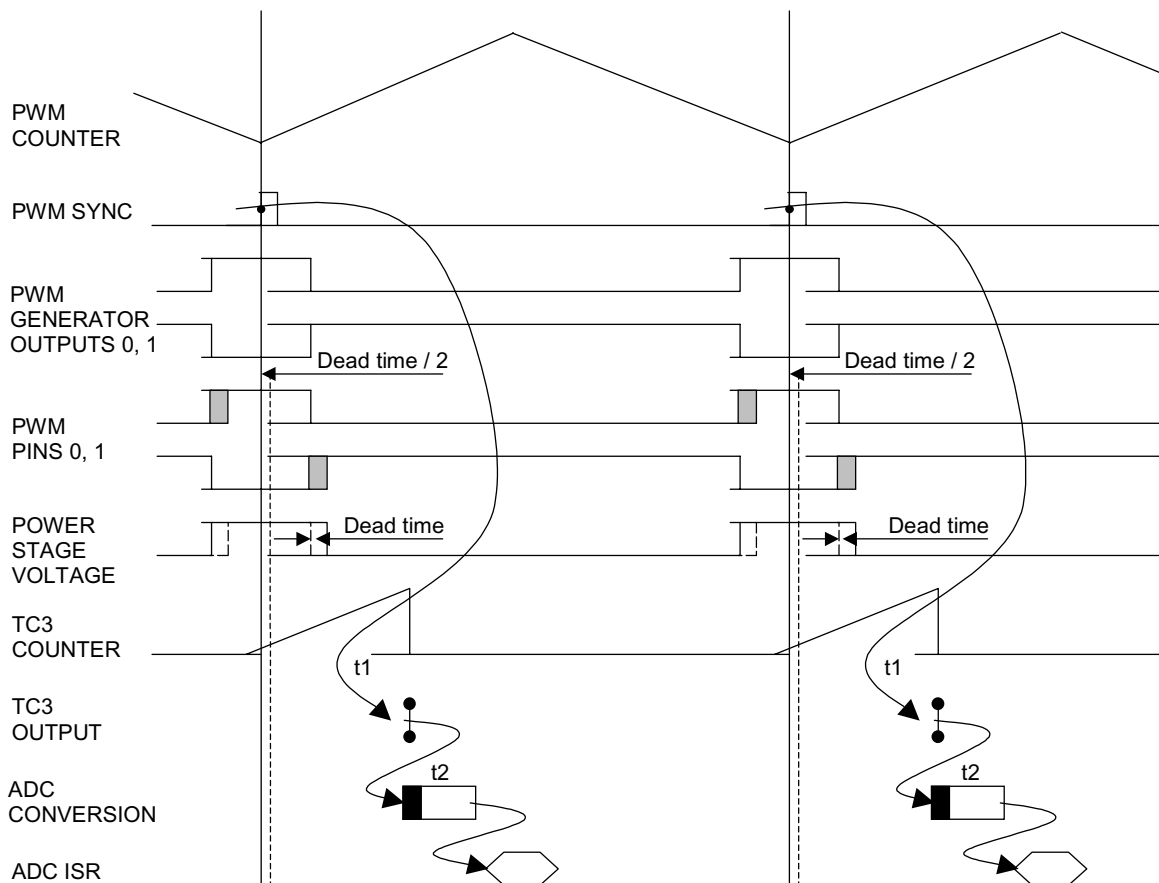

Figure 7-13. Time Diagram of PWM and ADC Synchronization

Phase currents are measured by shunt resistors at each phase. A voltage drop on the shunt resistor is amplified by an operational amplifier and shifted up by 1.65V. The resultant voltage is converted by the ADC; see [Figure 7-14](#) and [Figure 7-15](#).

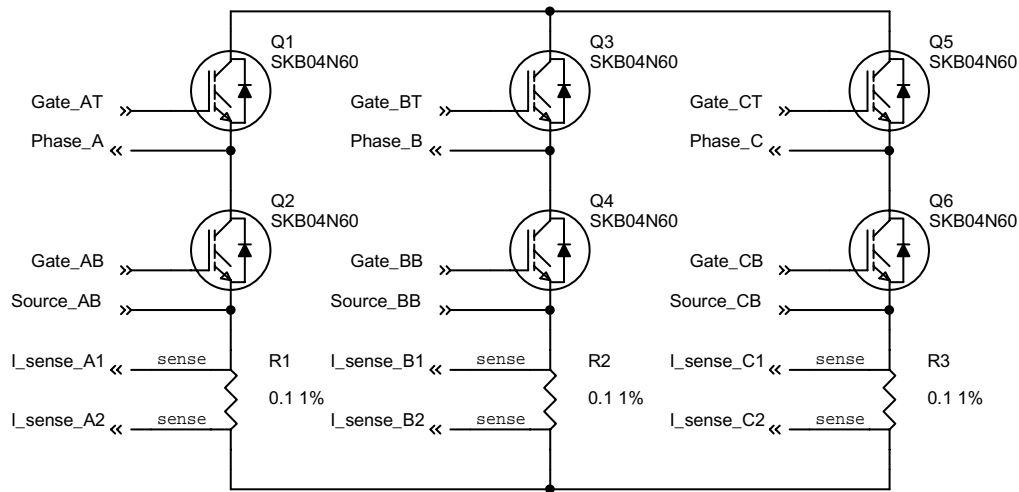

Figure 7-14. 3-Phase Bridge with Current Shunt Resistors

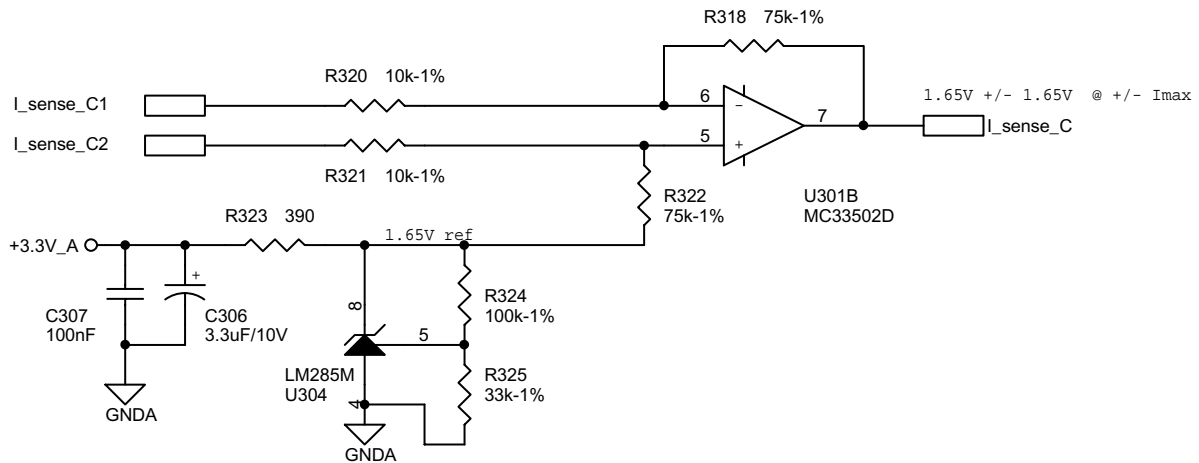

Figure 7-15. Current Amplifier for Phase C

The current cannot be measured at the current sense resistors at an arbitrary moment. This is because current only flows through the shunt resistor (for example, R1 corresponding to Phase A) if transistor Q2 is switched on. Only at that instant can the Phase A current be measured. Correspondingly, the current in Phase B can only be measured if transistor Q4 is switched on, and the current in Phase C can only be measured if transistor Q6 is switched on. In order to get an actual instant of current sensing, voltage shape analysis must be performed.

Voltage shapes of two different PWM periods are shown in [Figure 7-16](#). These voltage shapes correspond to center-aligned PWM sinewave modulation. As shown, the best instant of current sampling is in the middle of the PWM period, where all bottom transistors are switched on. However, all three currents cannot be measured at an arbitrary voltage shape. *PWM period II* in [Figure 7-16](#) shows an instant when the bottom transistor of Phase A is on for a very short time. If the time on is shorter than a certain critical time, the current cannot be

correctly measured. The specific critical time is given by the hardware configuration (transistor commutation times, response delays of the processing electronics, etc.). In the 3-phase ACIM application, two PWM periods are always longer than the critical pulse width. Therefore, only two currents are measured and the third current is calculated from this equation:

$$0 = i_A + i_B + i_C \quad \text{EQ. 7-12}$$

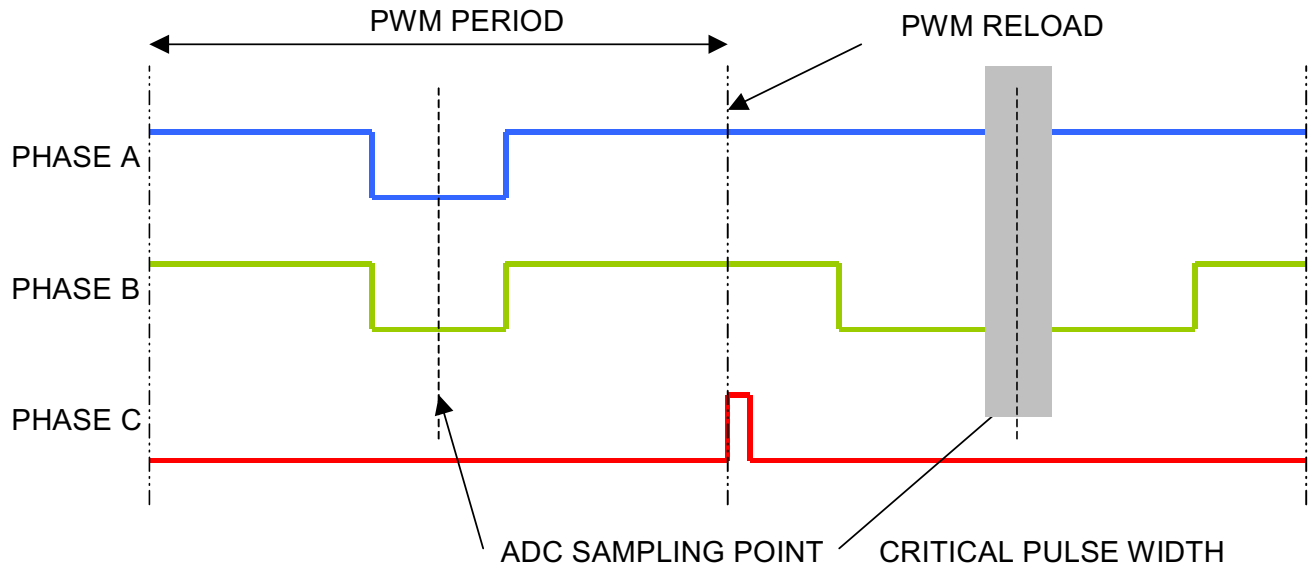

Figure 7-16. Voltage Shapes of Two PWM Periods

Figure 7-17. 3-Phase Sinewave Voltages and Corresponding Sector Values

The current that cannot be measured is calculated. The simplest technique is to calculate the current of the most positive phase voltage, where the bottom PWM is switched on for the shortest time. For example, Phase A generates the most positive voltage within section 0 - 60°, Phase B within the section 60° - 120°, etc.; see [Figure 7-17](#).

In the case presented, the output voltages are divided into six sectors; see [Figure 7-17](#). The current is then calculated according to the actual sector value.

Sectors 1, 6:

$$i_A = -i_B - i_C \quad \text{EQ. 7-13}$$

Sectors 2, 3:

$$i_B = -i_A - i_C \quad \text{EQ. 7-14}$$

Sectors 4, 5:

$$i_C = -i_B - i_A \quad \text{EQ. 7-15}$$

Notes: The sector value is used only for current calculation and has no other meaning at the sinewave modulation. But if any type of the space vector modulation is used, the sector value can be obtained as a part of space vector calculation and used for phase current measurement.

7.6.2 Voltage Sensing

The resistor divider network in [Figure 7-18](#) is used to sense the DCBus voltage. The voltage signal is divided down to the 3.3V level and is ready for further processing. DCBus voltage does not change rapidly. It is almost a constant, with ripple caused by the structure of the power supply. If a bridge rectifier for conversion of the AC line voltage is used, the ripple frequency is twice the AC line frequency. Ripple amplitude should not exceed 10% of the nominal DCBus value if the power stage is designed correctly.

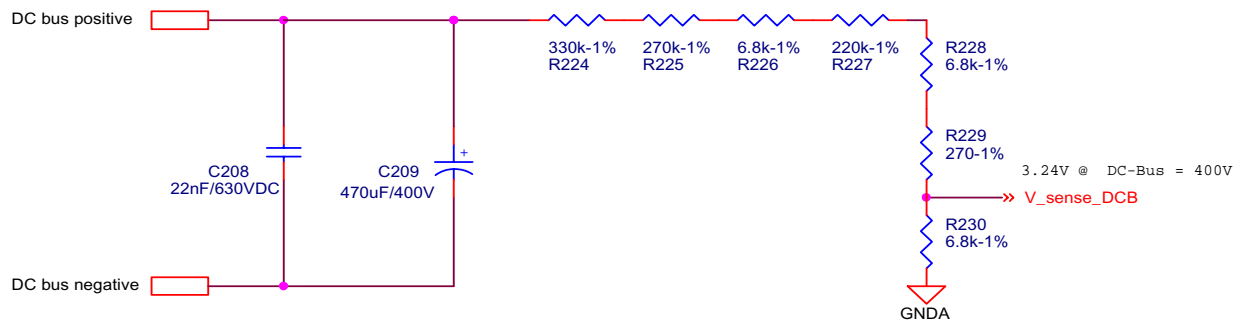

Figure 7-18. DC-Bus Voltage Sensing

The measured DCBus voltage must be filtered in order to eliminate noise. One of the easiest and fastest techniques is a first order filter, which calculates the average filtered value recursively from the last two samples and a coefficient C:

$$u_{DCBusFilt}^{(n+1)} = (Cu_{DCBusFilt}^{(n+1)} - Cu_{DCBusFilt}^{(n)}) - u_{DCBusFilt}^{(n)} \quad \text{EQ. 7-16}$$

To speed up initialization of voltage sensing, the filter has an exponential dependence with a constant of 1/N samples and a moving average filter that calculates the average value from the last N samples is used:

$$u_{DCBusFilt} = \sum_{n=1}^{-N} u_{DCBus}(n) \quad \text{EQ. 7-17}$$

7.6.3 Power Module Temperature Sensing

The measured power module temperature is used for thermal protection. The hardware realization is shown in **Figure 7-19**. The circuit consists of four diodes connected in series, a bias resistor, and a noise suppression capacitor. The four diodes have a combined temperature coefficient of 8.8 mV/°C. The resulting signal, *Temp_sense*, is fed back to an A/D input where software can be used to set safe operating limits. In the application presented, the temperature (in Celsius) is calculated according to the conversion equation:

$$\text{temp} = \frac{\text{Temp_sense} - b}{a} \quad \text{EQ. 7-18}$$

where:

- temp = Power module temperature in Celsius
- Temp_sense = Voltage drop on the diodes, which is measured by the ADC
- a = Diode-dependent conversion constant (a = -0.0073738)
- b = Diode-dependent conversion constant (b = 2.4596)

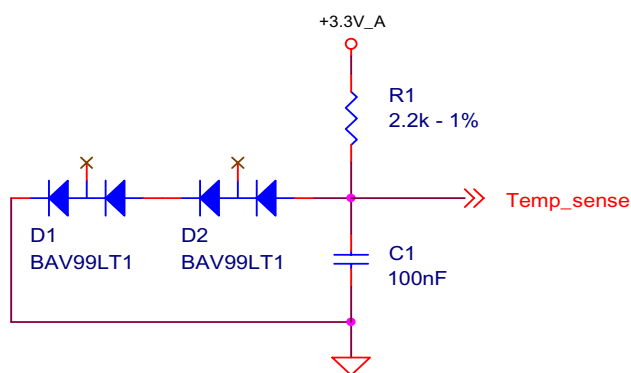

Figure 7-19. Temperature Sensing

7.7 RUN / STOP Switch and Button Control

The RUN / STOP switch is connected to GPIOE5. The state of the RUN / STOP switch can be read directly from the GPIO Data Register.

User buttons are also connected to GPIO pins. The state of buttons are read periodically from the GPIO Data Register. The EVM boards do not resolve the button contact bouncing, which may occur while pushing and releasing the button, so this issue must be resolved by software.

The reading of buttons are masked by software methods. The following algorithm is used to check the state of the desired GPIO pins.

The level of a GPIO may be LOW or HIGH. When the button is pressed, the logical level LOW is applied on the GPIO pin and the scanning routine detects the low level; it also sets the corresponding *buttonStatus* bit. Due to contact bounces, the routine disables the scanning process and sets the debounce counter to a predefined value, just after the low level is detected. The variable *buttonStatus* represents the interrupt flag. Using the 56F8346's software timer, the *ButtonProcessingInterrupt* function is periodically called, as shown in [Figure 7-20](#). The function *ButtonProcessingInterrupt* decrements the debounce counter and if the counter is 0, the reading of GPIO pins is again enabled. The button press is checked by the *ButtonEdge* function; see [Figure 7-20](#). When the variable *buttonStatus* is set, the *ButtonEdge* function returns "1" and clears *buttonStatus*. When the variable *buttonStatus* is not set, the *ButtonEdge* function returns "0".

According to the *ButtonProcessing* calling period, the value of the debounce counter should be set close to 180ms. This value is sufficient to prevent multiple sets of *buttonStatus* bits, due to contact bounces.

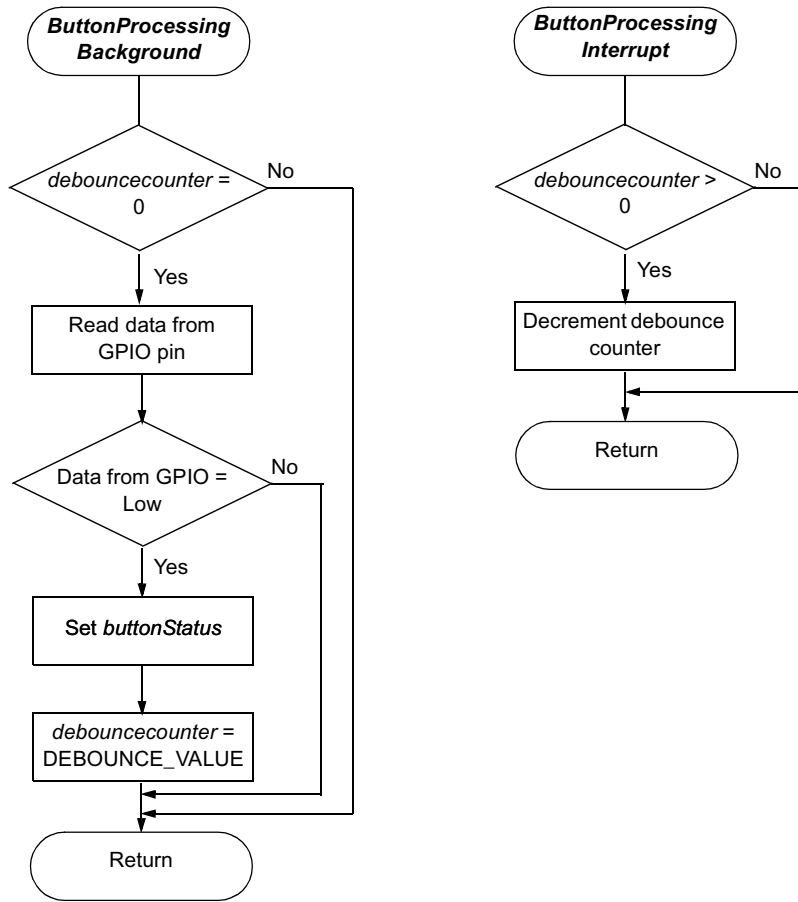

Figure 7-20. Button Control - *ButtonProcessingBackground* and *ButtonProcessingInterrupt*

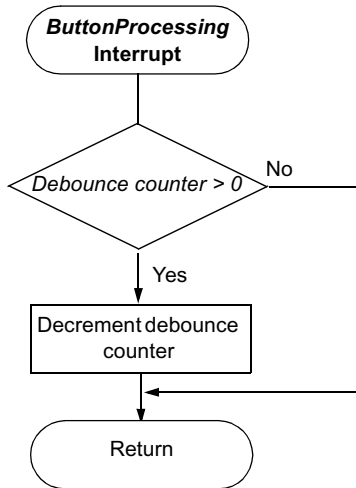

Figure 7-21. Button Control - *ButtonProcessing*

8. Processor Expert (PE) Implementation

This section describes PE implementation for targeting the 56F83xxEVM.

PE is a collection of beans, libraries, services, rules and guidelines. This software infrastructure is designed to let a 56F80x or 56F8300 software developer create high-level, efficient and portable code. The following section describes how the 3-phase AC induction motor vector control application was written under the PE.

8.1 Beans and Library Functions

The 3-phase AC induction motor vector control application uses the following drivers:

- ADC bean
- Quad Timer bean
- Quadrature Decoder bean
- PWM bean
- PC master software bean

The 3-phase AC induction motor vector control application uses the following library functions:

- *fluxmodel* (rotor flux calculation, *MC_FluxModel* bean)
- *cptrfmClarke* (forward Clarke transformation, *MC_ClarkePark* bean)
- *dqestabl* (d-q system establishment, *MC_DQestabl* bean)
- *decoupling* (stator voltage decoupling, *MC_Decoupling* bean)
- *cptrfmParkInv* (inverse Park transformation, *MC_ClarkePark* bean)
- *svmElimDcBusRip* (DCBus ripple elimination, *MC_SpaceVectorMod* bean)
- *svmPwmIct* (space vector modulation, *MC_SpaceVectorMod* bean)
- *rampGetValue* (ramp generation, *MC_Ramp* bean)
- *controllerPItype1_asmSc* (PI controller, *MC_Controller* bean)

8.2 Beans Initialization

Each peripheral on the hybrid controller chip or on the EVM board is accessible through a bean. The bean initialization of each peripheral used is described in this section. For a more detailed description of drivers, see [13], [References](#).

To use a bean, follow these steps:

- Add the required bean:
 - Right click *Beans* under the *Processor Expert* tab in the project window, select *Add Beans*
 - When PE's *Bean Selector* window opens, select the desired bean
- Configure the added bean
- Call the bean's *init* function, or use PE initialization, by selecting *Call init* in the CPU *init* code

Access to individual driver functions is provided from *PESL* support by the *ioctl* or *PESL* function call. To enable access to these functions, enable *PESL support* in the *CPU bean* used.

8.3 Interrupts

When configuring a bean in PE, the user defines the callback functions called during interrupts.

8.4 PC Master Software

PC master software was designed to provide a debugging, diagnostic and demonstration tool for development of algorithms and applications. It consists of a component running on a PC and a second component running on the target hybrid controller, connected by an RS-232 serial port. A small program is resident in the hybrid controller that communicates with PC master software to parse commands, return status information to the PC, and process control information from the PC. PC master software executing on the PC uses Microsoft Internet Explorer as the user interface to the PC.

To enable the PC master software operation on the hybrid controller target board application, add the *PC_Master* bean to the application. The *PC_Master* bean is located under *CPU External Devices -> Display* in PE's *Bean Selector*.

The PC master bean automatically includes the SCI driver and installs all necessary services. This means there is no need to install the SCI driver, because the *PC_Master* bean encapsulates its own SCI driver.

The default baud rate of SCI communication is 9600 and is set automatically by the PC master software driver.

Part of the PC master software is also a recorder, which is able to sample the application variables at a specified sample rate. The samples are stored to a buffer and read by the PC via an RS-232 serial port. The sampled data can be displayed in a graph or the data can be stored. The recorder behaves like a simple on-chip oscilloscope with trigger / pretrigger capabilities. The size of the recorder buffer and the PC master recorder time base can be defined in the *PC_Master* bean.

The recorder routine must be called periodically in the loop in which samples are to be taken. The following line must be added to the loop code:

```
pcmasterdrvRecorder(); /* Free Master recorder routine call */
```

A detailed description of PC master software is provided in PE documentation.

The actions controlled by PC master software are:

- Take over the PC remote control
- Run / Stop control
- Motor speed set point

Variables read by PC master software by default and displayed to the user are:

- Required speed
- Actual motor speed
- PC remote control mode
- Run / Stop status
- Drive Fault status
- DCBus voltage level
- Identified power stage boards
- System status

The profiles of required and actual speed can be seen in the speed scope window.

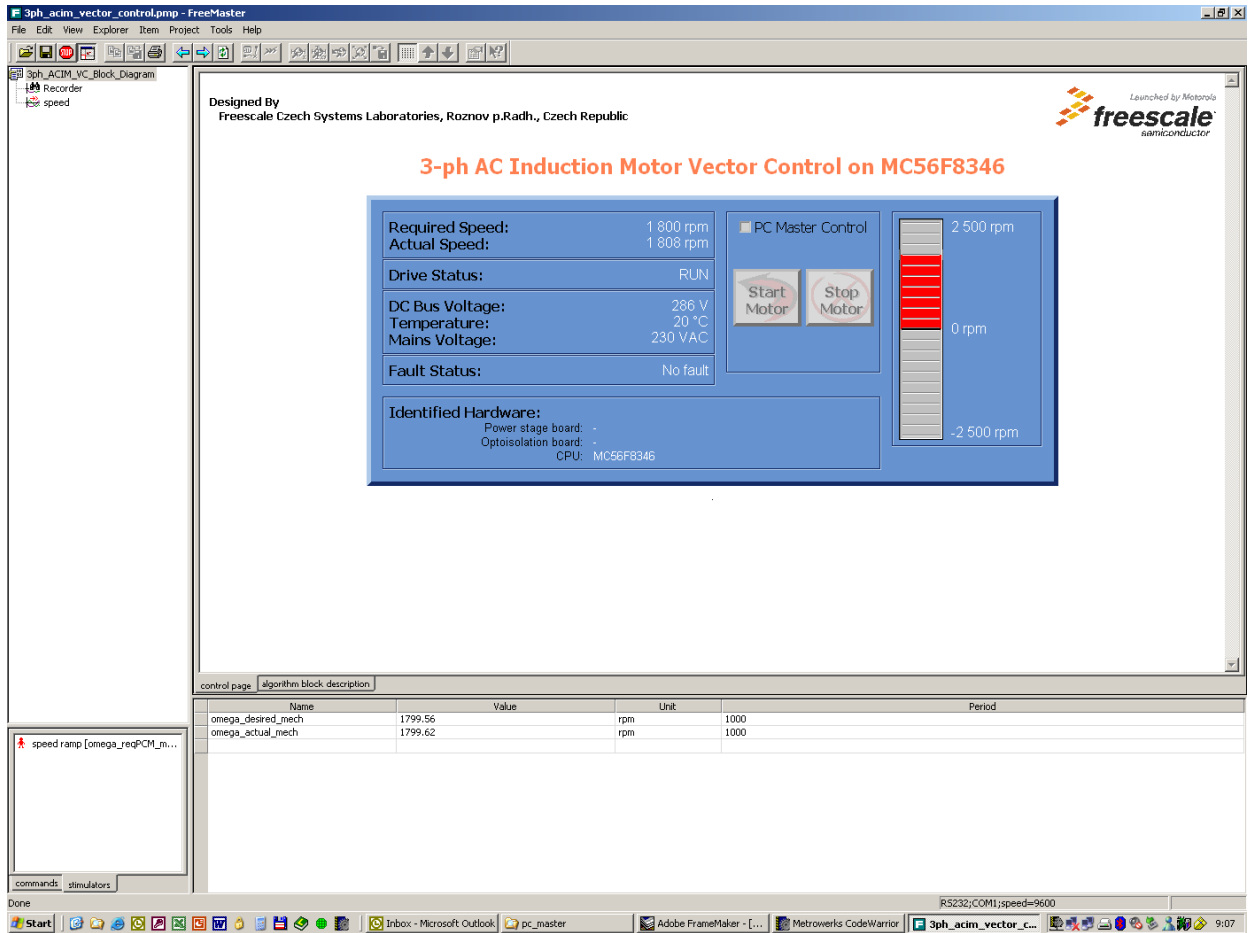

Figure 8-1. PC Control Window

9. Hybrid Controller Use

Table 9-1 shows how much memory is used to run the 3-phase AC induction motor vector control application. The PC master software's recorder buffer is set to 512 words and the bulk of the hybrid controller's memory is still available for other tasks.

Table 9-1. RAM and FLASH Memory Use for PE 2.94 and CodeWarrior 6.1.2

Memory (In 16 bit words)	Available for 56F8300 Hybrid Controllers	Used Application + Stack	Used Application without PC MasterSoftware, SCI
Program Flash	64K	10066	5610
Data Flash	4K	20	7
Program RAM	2K	0	0
Data RAM	4K	1156 + 512 stack	448 + 512 stack

10. References

- [1.] Bose, K. B. (1997). *Power Electronics and Variable Frequency Drives*, IEEE Press, ISBN 0-7803-1061-6, New York.
- [2.] Caha, Z.; Cerny, M. (1990). *Elektrické pohony*, SNTL, ISBN 80-03-00417-7, Praha.
- [3.] Subrt, J. (1987). *Elektrické regulacní pohony II*, VUT Brno, Brno.
- [4.] Vas, P. (1998). *Sensorless Vector and Direct Torque Control*, Oxford University Press, ISBN 0-19-856465-1, New York.
- [5.] *56800 Family Manual*, DSP56F800FM, Freescale Semiconductor, Inc.
- [6.] *DSP56F800 User Manual*, DSP56F801-7UM, Freescale Semiconductor, Inc.
- [7.] *56F8300 Peripheral User Manual*, MC56F8300UM, Freescale Semiconductor, Inc.
- [8.] *56F83xx Evaluation Module Hardware User's Manual* for the specific device being implemented, MC56F83xxEVMUM, Freescale Semiconductor, Inc.
- [9.] *56F805 Evaluation Module Hardware User's Manual*, DSP56F805EVMUM, Freescale Semiconductor, Inc.
- [10.] *3-Phase AC/BLDC High-Voltage Power Stage User's Manual*, MEMC3PBLDCPSUM, Freescale Semiconductor, Inc.
- [11.] *Freescale Embedded Motion In-Line Optoisolation Box User's Manual*, MEMCILOBUM, Freescale Semiconductor, Inc.
- [12.] *3-Phase ACIM Vector Control using Processor Expert Targeting Document*, 8300ACIMTD, Freescale Semiconductor, Inc.
- [13.] Freescale Software Development Kit documentation available at:
www.freescale.com

How to Reach Us:

Home Page:

www.freescale.com

E-mail:

support@freescale.com

USA/Europe or Locations Not Listed:

Freescale Semiconductor
Technical Information Center, CH370
1300 N. Alma School Road
Chandler, Arizona 85224
+1-800-521-6274 or +1-480-768-2130
support@freescale.com

Europe, Middle East, and Africa:

Freescale Halbleiter Deutschland GmbH
Technical Information Center
Schatzbogen 7
81829 Muenchen, Germany
+44 1296 380 456 (English)
+46 8 52200080 (English)
+49 89 92103 559 (German)
+33 1 69 35 48 48 (French)
support@freescale.com

Japan:

Freescale Semiconductor Japan Ltd.
Headquarters
ARCO Tower 15F
1-8-1, Shimo-Meguro, Meguro-ku,
Tokyo 153-0064, Japan
0120 191014 or +81 3 5437 9125
support.japan@freescale.com

Asia/Pacific:

Freescale Semiconductor Hong Kong Ltd.
Technical Information Center
2 Dai King Street
Tai Po Industrial Estate
Tai Po, N.T., Hong Kong
+800 2666 8080
support.asia@freescale.com

For Literature Requests Only:

Freescale Semiconductor Literature Distribution Center
P.O. Box 5405
Denver, Colorado 80217
1-800-441-2447 or 303-675-2140
Fax: 303-675-2150
LDCForFreescaleSemiconductor@hibbertgroup.com

Information in this document is provided solely to enable system and software implementers to use Freescale Semiconductor products. There are no express or implied copyright licenses granted hereunder to design or fabricate any integrated circuits or integrated circuits based on the information in this document.

Freescale Semiconductor reserves the right to make changes without further notice to any products herein. Freescale Semiconductor makes no warranty, representation or guarantee regarding the suitability of its products for any particular purpose, nor does Freescale Semiconductor assume any liability arising out of the application or use of any product or circuit, and specifically disclaims any and all liability, including without limitation consequential or incidental damages. "Typical" parameters that may be provided in Freescale Semiconductor data sheets and/or specifications can and do vary in different applications and actual performance may vary over time. All operating parameters, including "Typicals", must be validated for each customer application by customer's technical experts. Freescale Semiconductor does not convey any license under its patent rights nor the rights of others. Freescale Semiconductor products are not designed, intended, or authorized for use as components in systems intended for surgical implant into the body, or other applications intended to support or sustain life, or for any other application in which the failure of the Freescale Semiconductor product could create a situation where personal injury or death may occur. Should Buyer purchase or use Freescale Semiconductor products for any such unintended or unauthorized application, Buyer shall indemnify and hold Freescale Semiconductor and its officers, employees, subsidiaries, affiliates, and distributors harmless against all claims, costs, damages, and expenses, and reasonable attorney fees arising out of, directly or indirectly, any claim of personal injury or death associated with such unintended or unauthorized use, even if such claim alleges that Freescale Semiconductor was negligent regarding the design or manufacture of the part.



Freescale™ and the Freescale logo are trademarks of Freescale Semiconductor, Inc. All other product or service names are the property of their respective owners. This product incorporates SuperFlash® technology licensed from SST.

© Freescale Semiconductor, Inc. 2005. All rights reserved.